

Routine Press Maintenance

This Chapter Sponsored by CASTOOL Tooling Solutions

www.Castool.com

The Need for Regular Inspection and Maintenance

The common enemies of the horizontal extrusion press are **gravity, friction, fatigue, dirt and foreign matter**. The horizontal position requires special support surfaces to bear the weight of components throughout the operating cycle. These bearing surfaces are subject to wear from constant friction, and to damage from dirt and foreign matter that are common around the press. Heavy equipment and tooling may be dropped on these surfaces, causing permanent damage. Lubricants and hydraulic fluids catch and hold dirt onto the critical surfaces.

Proper alignment of the press is critical to minimizing wear, and also to minimizing stresses on the press structure and components. Although press components may be oversized for long life, a seemingly minor misalignment may multiply the stresses involved and result in premature failure. For example, misalignment of the main crosshead may result in excessive wear to the main ram, main cylinder packing, and main cylinder bushing; and to the crosshead cylinders, bushings, and packings. The crosshead cylinder rods may fail due to fatigue loading.

Alignment of the stem, container and tooling stack with the press platen and pressure ring are likewise critical to extrusion tolerances as well as to the life of the container lining, container shift cylinders, and die carriers. Operating with badly worn container guides makes proper alignment impossible and eventually results in excessive costs for poor quality, downtime and repair costs.

The guide ways and shoes for the container and crosshead must be protected from dirt and foreign matter as well as misalignment. Dirt is easily air-blown or tracked on the shoes of workers. Careless handling of heavy tooling, bars, or hand tools can cause a permanent nick or dent to these surfaces. The same is true for the main ram and for crosshead or container cylinder rods.

Effective maintenance must begin with educating all workers about these hazards and their consequences, as well as proper preventive measures. Minor damage must be recognized by inspection and corrected before secondary damage results.

The Voice of Experience:

One “old-timer” with many years experience in press maintenance offered this advice before he retired: “Think of the press as a small child who isn’t yet able to talk. So we must care for him gently, and listen to him to understand even the smallest problem. We should clean him constantly and carefully, and take care of even the smallest leakage. In return for this, we will be pleased with his performance.”

Scheduled Maintenance

Planned maintenance of equipment on a regular basis allows for the most efficient use of both workers and machine. With scheduled downtime, work can be performed when all the necessary skills, parts, supplies, and test equipment are available. Production workers may be scheduled off or assigned to other duties. Many different tasks may be carried out at the same time. Work may be performed more carefully. By recording historical wear rates, certain components may be replaced before unplanned breakdowns occur.

Sponsor's advertisement -- more information: www.castool.com

BETTER PROFILES FASTER

TWIN CELL

HEAT DIES ACCURATELY, SAFELY AND QUICKLY



CE APPROVED

CASTOOL
TOOLING SYSTEMS

DUMMY BLOCKS
H-13 (1.2344) AND TUFF-TEMPER



RRB MARATHON HPR



The perfect die requires the die and liner temperature to be stable from the first to the last billet.

QR CONTAINER

MAINTAINS STABLE LINER TEMPERATURE BY DISSIPATING HEAT AS GENERATED BY THE PROCESS



TOOLING SPECIALISTS

<ul style="list-style-type: none"> Relines Stems Clean-Out Blocks Shear Blades 	<ul style="list-style-type: none"> Billet Shears Die Rings (Reclaimed) Piercing Mandrels Indirect Tooling
--	---

sales@castool.com www.castool.com





Scan here to access Castool web site >>



By contrast, “breakdown maintenance” must depend on the workers and skills available at the moment of breakdown, and delays often occur while the appropriate people, repair parts, and supplies are rounded up. Work is seldom performed well or efficiently, and many items that could have been done at the same time must be delayed until the next unplanned breakdown.

Well-organized plants schedule press repairs on a regular frequency, usually taking “PM” (preventive maintenance) or “down-days” weekly or semi-weekly. Tasks are scheduled according to items noted on daily inspections, plus items scheduled at a frequency determined from past experience. Monthly, quarterly, semi-annual, and annual PM periods will take longer according to the additional checks included in the established schedules.

It is not possible to set an overall “standard” frequency for preventive maintenance; it is different for each press and for each company. Even though suggested maintenance intervals are given in **Chapter A - Maintenance Schedules**, these are indicative only and should be adjusted based on your actual situation: the design of your equipment, its age, its actual history, and requirements of your production schedule

The frequencies suggested here are based on the opinions of various equipment suppliers and experienced extrusion plant engineers, and they can be a good reference for establishing your own schedules and program.

Predictive Maintenance

Predictive maintenance uses modern technology to determine a machine's condition while it is operating, records the information, and analyzes the recorded information to predict the optimum time and extent of repair needed to keep the machine in its best condition.¹

Examples of Predictive Maintenance of Extrusion Presses include:

- hydraulic oil analysis
- Magnetic Particle Inspection and Ultrasonic Testing of press components to detect fatigue cracks
- infrared scans of electrical equipment to look for overheating
- vibration monitoring



Figure 1-1: Ultrasound test of main cylinder
(Photo courtesy of Presezzi Extrusion)

Preventive Maintenance

Preventive Maintenance (PM) describes any scheduled maintenance task which is performed to prevent unplanned maintenance or breakdown. PM usually involves routine, repetitive tasks, and may be performed by maintenance people or operators. The list of PM tasks for any plant is constantly changing, according to records of breakdown-causing problems as well as items found on other PM's.

Included in **Chapter A** are suggested Maintenance Schedules for extrusion press plants. These can be used as the basis for establishing a PM program if one does not already exist. (Copies of these schedule sheets are also available in Spreadsheet format; contact the author by email for free copies.)

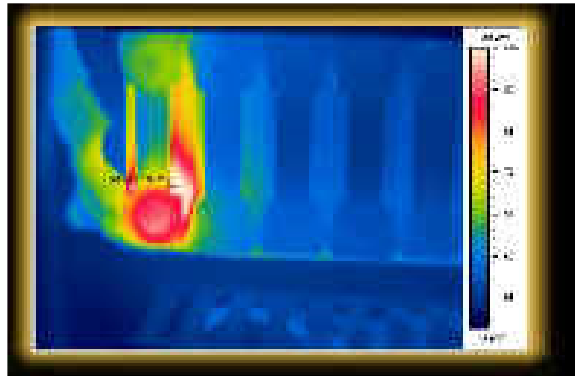

Figure 1-2: Infrared view of an overheated fuse block

Preventive Maintenance Planning

After the Preventive Maintenance program is in place, effective performance requires planning for each PM. This means devoting the time and manpower to analyze each task and its frequency; then identifying the personnel, tools, parts, supplies, and test equipment needed for each task; and, finally, assuring that all are available for the PM period. Without this kind of planning, some tasks will be left incomplete or skipped entirely, and the PM program will be a failure.

Daily Walk-Around Inspection. There is no substitute for a daily operating check of the press, just as an airplane pilot or truck driver makes a routine "walk around" check of his equipment. Without stopping the press, an appropriately trained supervisor, maintenance person or operator should check the press thoroughly, noting items which may safely be observed while the press is operating. The items observed will then be scheduled for repair according to the urgency of the problems. A suggested check list for this daily inspection is included in the Preventive Maintenance Schedule. In general:

¹ Eidson, B., "Improving Equipment Effectiveness Through Total Productive Manufacturing," *Proceedings of 6th International Aluminum Extrusion Technology Seminar*, (1996).

- ⇒ Look at the motions of the main moving parts: container, crosshead, die changer, butt shear. Are movements generally smooth and parallel?
- ⇒ Look at alignment on a discard butt (or special scribed-dummy-die butt): a quick inspection will indicate alignment and condition of the container.
- ⇒ Look at the tooling carrier or die slide: wear or build-up which may result in premature wear will be evident here. Is the die changer or carrier clean?
- ⇒ Look at the container, ram stem, and fixed dummy block: signs of buildup, misalignment, bent ram, or other problems will appear here.
- ⇒ Look at the main ram and auxiliary cylinders: oil leaks or damage to rods or bushings may be spotted.
- ⇒ Look over the hydraulic system: for leaks, vibration, low oil, excess heat, changes in oil temperature, or change in oil condition; all are signs of trouble ahead.
- ⇒ Look for changes: what's different from yesterday, and why?

*Note: also see the check-sheet-based approach by David Turnipseed in *The Voice of Experience*, pages 1-9 to 1-23.*

Mechanical Maintenance

Main Cylinder and Packing. The main cylinder packing should be observed for oil leaks, in particular for any sudden increase in leakage, which may indicate damage to the packing or main ram surface. Packing should be checked for embedded particles, which may score the surface of the main ram. When tightening the packing, the gland ring must be tightened evenly all around. Spacers made of keystone may be used to measure that it is being tightened uniformly.

Periodically the main cylinder should be checked for possible excess wear to the main cylinder bushing, as follows: extend the main ram just far enough to accommodate a machinist's level on the ram surface (about 18"). At this point the main ram should be fully supported by the main ram bearing bushing. The main ram should be level to the same tolerance as the main cylinder: 0.0005 in/ft (0.04 mm/meter). If the main cylinder's platen surface is perpendicular and the ram is not level, the main ram bearing bushing is likely worn and may require replacement. The guide shoes of the moveable crosshead should just be touching the guide ways in this position.

Main Ram. The main ram must be checked for nicks or scratches, which will damage packing and increase oil leakage. If nicks or scratches occur, the surface must be immediately polished smooth with a stone, then washed to remove the residue. Follow up carefully -- watch the area closely and repack as soon as convenient, or immediately if scoring persists.

Tie Rods. Check prestress of the tie-rods by feeling for clearance between the inside nuts and flanges while the press is under load. Any clearance, even 0.001 inch (0.025 mm) indicates loss of prestress. Each nut should also be match-marked to the platen so that any rotation of the nut will be apparent.

Follow the press manufacturer's instructions for loosening nuts and adjusting the prestress of tie rods. In the absence of such manufacturer's instructions, the following general procedure may be useful for presses with 4 nuts per tie-rod:

Prestressing of tie rods is usually accomplished by raising the press tonnage to 10% above the rating and using the main ram to stretch the rods, then tightening the inside nuts and locking them to retain the prestress.

The inside nuts should remain tight, even under full load, and should not allow insertion of even a 0.001 inch feeler gauge (0.025 mm) between the nut and flange. Likewise when the load is relaxed there must be no clearance between the platen and outside nuts. With sleeved tie-rods, no space is permitted between the sleeve and platen. Any such space indicates a loss of pre-stress and requires re-torquing of nuts and rechecking of squareness.

*Note also the recommended procedures for detecting, monitoring, and repairing cracked tie rods, in **Chapter 4 - Inspecting and Repairing Major Components**.*

Front Platen. The condition of the front platen pressure ring is critical to die performance and so should be checked often with straightedge and feeler gauge. The primary concerns are looseness, cracking, or distortion; for example “coining”, in which a permanent impression is made in the ring. Repair or replace the pressure ring if any damage is detected. The old ring may sometimes be returned to a smooth and parallel condition by grinding and shimming.

Crosshead, Guideways, and Guide Shoes. Correct adjustment of the crosshead is discussed in *Chapter 2- Press Alignment*. In addition to alignment, the guide ways must be checked for nicks or other damage to the surfaces, for example damage due to dropped tooling. Another concern is brass pick-up on the ways, indicating possible poor lubrication, or that the brass shoes are not making proper contact due to misalignment. Guide shoes should be removed and fully inspected periodically; replace or re-machine as needed. Many presses are fitted with wipers to remove dirt and foreign matter ahead of the shoes; check these wipers for proper alignment.

Crosshead Cylinders. Check for excessive oil on the rods, which may indicate damage to packing or bushings. Check clearances around the rods (also when repacking) which may indicate excess wear of bushings. Check for nicks, bending, or other damage to rods, which may damage the packing. Check for oil leaks at cylinder connections. Check that the attachment nuts to the crosshead are tight, including while under load. Check for excess heat, which may indicate that oil is by-passing the piston head (cylinder rebuild needed); hold the crosshead against main cylinder at full pressure and check for temperature rise.

Ram Stem. In addition to the alignment checks indicated in *Chapter 2 - Press Alignment*, the ram stem should be checked often for signs of bending, cracks, or upset, due to its critical nature and to the excessive stresses involved. Check its straightness with a straightedge. Check the pressure plate to which the stem is mounted for damage, deflection, or “coining”, using a straightedge and feeler gauges; remove and re-grind flat if damaged. The seat must also be clean. The stem retention ring or other stem mounting devices must be properly tightened.

Check the stem and fixed dummy block often for signs of build-up or excessive wear. Any contact forces are transmitted back to the main cylinder and may result in premature wear of the main ram and bushings, and to the crosshead cylinders as well.

Container Holder, Guides, and Guide Shoes. Correct adjustment of the container is discussed in *Chapter 2 - Press Alignment*. In addition to alignment, the guide ways must be checked for nicks or other damage to the surfaces, for example damage due to dropped tooling. Another concern is brass pick-up on the ways, indicating that the brass shoes are not making proper contact due to misalignment. Guide shoes should be removed and fully inspected periodically; replace or re-machine as needed. Many presses are fitted with wipers to remove dirt and foreign matter ahead of the shoes; check these wipers for proper alignment.

Check the condition and tightness of container keys, lock rings, and/or retainer bolts, according to the design of the container holder. Check for signs of relative movement between the container and holder, which may indicate inadequate keying and locking, or possible structural cracks or wear. Re-machining or replacement may be necessary.

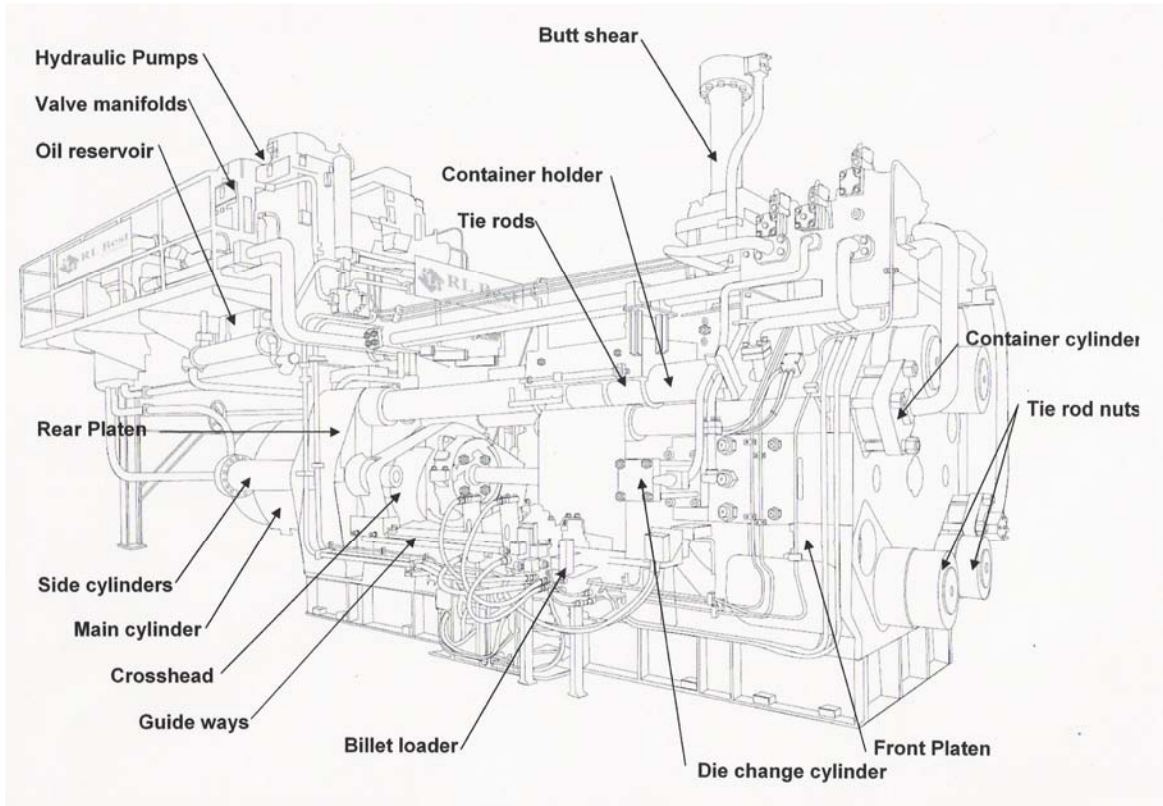

Figure 1-3: Illustration of press components (Drawing courtesy of RL Best)

Container Cylinders. Check for excessive oil on the rods, which may indicate damage to packing or bushings. Check clearances around the rods (also when repacking) which may indicate excess wear of bushings. Check for nicks, bending, or other damage to rods, which may damage the packing. Check for oil leaks at cylinder connections. Check that the attachment nuts to the container are tight, including while under load. Check for excess heat, which may indicate that oil is by-passing the piston head; hold the container against the die stack at full pressure and check for temperature rise.

Butt Shear. Correct adjustment of the butt shear with the tooling stack is discussed in **Chapter 2 - Press Alignment**. Check for wear in the blade guides, which may allow the blade to deflect away from the die stack. Check the condition of the blade; repair or replace as needed. Nicks and other blade damage may indicate misalignment or poor condition of the tooling stack. The die stack must be completely uniform in overall dimensions; variations in excess of 0.020" (0.5 mm) are likely to cause damage to the butt shear blade. A plant standard for overall tooling dimensions should be maintained for each press and rigidly followed to avoid problems; non-standard tooling must be modified or discarded.

Different designs and devices are available to insure correct positioning of the die stack. Cylinder-operated lever clamps are often devised to hold the die stack securely during shearing. Also, the condition of the die carrier or die changer pocket must be inspected often to maintain keys and critical dimensions in the proper condition. Build-up of aluminum or dirt will also increase the risk of misaligned tooling.

The butt shear hydraulic cylinder should be maintained as follows: Check for excessive oil on the rod, which may indicate damage to packing or bushings. Check for nicks, bending, or other

damage to the rod, which may damage packing. Check for oil leaks at cylinder connections. Check that the attachment nuts to the shear blade are tight. Check for excess heat, which may indicate that oil is by-passing the piston head. Check for excess play in blade guides (depending on the design), which may allow unusual strain on the cylinder.

Note that improved butt shear designs are available for retro-fit to older presses. (See **Chapter C - Modernizing Older Presses.**) One important feature is addition of a *butt knocker*, which in some cases may be retrofitted to an existing butt shear. It is usually a cylinder-actuated device which sweeps the shear area after every stroke to insure separation of the butt.

Another way to insure good separation of sheared butts is the automatic application of high-tech, high temperature lubricants/parting compounds to the shear blade. A spray is actuated automatically, for example after each five billets (see page 1-8).

Die Changer. Correct adjustment of the die stack and die changer is discussed in **Chapter 2 - Press Alignment.** Check all bolts and nuts for tightness. Check brass guide ways for wear or scoring; look for looseness of the die slide or carrier in the guides. Check critical die pocket dimensions for wear or build-up; restore correct dimensions as needed before problems arise with the butt shear or press alignment. Check for signs of relative movement between tooling and holder during shearing, which may require tightening, or build-up and re-machining.

Check the die changer hydraulic cylinder(s) as follows: Check for excessive oil on the rod, which may indicate damage to packing or bushings. Check for nicks, bending, or other damage to the rod, which may damage packing. Check for oil leaks at cylinder connections. Check that the attachment nuts to the changer or carrier are tight. Check for excess heat, which may indicate that oil is by-passing the piston head. Check for excess play in die changer guides (depending on the design), which may allow unusual strain on the cylinder(s).

Check for wear or scoring where the die changer passes along the front platen. If there is scoring due to contact, grind the area smooth and lubricate it; adjust or shim the slides or “gibs” to eliminate the contact.

Billet Loader. Work on the billet loader is one of the most dangerous areas of press maintenance. Special jigs or fixtures are needed to block up the loader in a safe working position and guard against its falling. Lock-out/tag-out procedures are especially critical when working on the billet loader.

Before working on a hydraulically-actuated loader, make sure there is no "stored energy" or pressure remaining in the hydraulic system. Serious injuries have occurred when loaders moved even though electric power was locked out.

Correct adjustment of the billet loader is indicated in **Chapter 2 - Press Alignment.** Check the loader for loose bolts and nuts. Check all pivot points for excessive play or wear; replace bushings as needed. Check the loader for structural damage due to collisions. (Many presses require stocking of a complete spare loader due to frequent collisions.)

Check the billet loader hydraulic cylinder(s) as follows: Check for excessive oil on the rod, which may indicate damage to packing or bushings. Check for nicks, bending, or other damage to the rod, which may damage packing. Check for oil leaks at cylinder connections. Check that the attachment nuts to the loader are tight. Check for excess heat, which may indicate that oil is by-passing the piston head. Check for excess play in the pivots, which may allow unusual strain on the cylinder(s).

On presses which still use loose dummy blocks, condition of the blocks and their match-up with the ram stem should also be checked. Alignment must be made with a dummy block in place.

Lubrication

General Press Lubrication. Lubrication of extrusion press components is generally not a complicated issue. The presence of oil mist, hydraulic leaks, and sprayed tooling lubricants usually result in a general oil film over the entire press area. It is more important to insure that dirt and foreign matter are not trapped on sensitive surfaces by this oil film.

The location and type of press lubrication points depends on the design of the press. The press manufacturer's original recommendations should be followed. Where the original lubrication instructions have been lost over the years, past practices are usually a sufficient guide. Routine lubrication maintenance consists of greasing all required locations, usually daily; and filling combination-type oiler units.

Recommended lubricants for **container and die changer guides** include: Chevron Delo Grease EP-2; Perma-Tech Cartridge Nova LC 130, part #107274; or Mystic JT6.

High-Temperature Lubrication for Press Tooling. Advancing technology has resulted in development of several new families of engineered lubricants and parting compounds which are useful for specific press applications:

Billet/Dummy Block Lubricants. The ends of pre-cut billets have traditionally been lubricated by painting with graphite dispersions, in a base of either kerosine or water. However, increasing use of fixed dummy blocks, combined with hot-sheared billets, has forced the development of automatically applied alternatives, for example after the billet is sheared. Presently there are three popular methods of applying lubricant to the surface between billet and dummy block:

- **Automatic spraying** of the dummy block with proprietary liquid parting compounds. An automatic applicator descends from above by means of a pneumatic cylinder to align with the dummy block during the press dead cycle; then a rotating nozzle applies lubricant to the face and edges of the dummy block. PLC or relay controls determine the frequency and duration of application, followed by a short air purge. Typically, the block is sprayed every 5 to 10 billets. The fluids applied are specially developed to facilitate separation and prevent aluminum build-up, without accumulation of chemicals on the die or tooling. Typical supplier: Amcol Corporation, Hazel Park, Michigan (Telephone 248-414-5700).
- **Flame application of carbon** (soot) to the billet face. The billet is paused at some point of its transfer to the press, while a carbon-rich flame applies a coating of "soot" to the billet end. An acetylene or Mapp-gas flame burns for 3 to 4 seconds with a visibly black smoke. (The air pollution aspect is a problem in some plants.) Typically, every billet is coated. Equipment source: most suppliers of hot billet shears offer an acetylene lubricator.
- **Electrostatic application of Boron Nitride (BN) powder** to the billet and/or other tooling surfaces. BN powders are expensive and must be applied carefully to minimize cost, so application is normally by electrostatic sprayer. Controls may be set to permit spraying intermittently – for example, every 3 to 5 billets. Typical suppliers:
 - Castool, Scarborough, Ontario, www.castool.com, (Telephone 416.297.1521)
 - Amcol Corporation, Hazel Park, Michigan, www.amcolcorp.com (Telephone 248.414.5700).

Butt Shear Lubricants. Fixed nozzles are positioned to apply lubricant to the edge of the shear blade, typically after every 5 to 10 billets. Control is automatic by means of a PLC or relay logic. Proprietary fluids are used. Typical supplier: Amcol Corporation, Hazel Park, Michigan (Telephone 248-414-5700).

Sawing Coolants/Lubricants. Aluminum sawing, whether hot sawing at the press, or cold sawing of profiles or billets, may be significantly improved by means of advanced coolant-lubricants developed at Boeing Aircraft Co. in years past. The surface-wetting and heat removal properties of these fluids allow a significant reduction in the quantity of lubricant needed, so there is less fluid left on the product being sawed. Blade life is dramatically improved, and the quality of cut is much better. A special low-volume applicator is required due to the small quantity used. Typical supplier: Amcol Corporation, Hazel Park, Michigan (Telephone 248-414-5700), www.amcolcorp.com.

Editor's Note: One goal of the Extrusion Press Maintenance Manual is to share the valuable know-how of experienced maintenance people. On the following pages we present expert advice that comes from many years of hands-on service. The first article concerns Daily Check Sheets and Preventive Maintenance procedures. While developed for a particular press, it is useful as a basis for developing your own check sheets. It is provided by David Turnipseed, a second-generation Maintenance Manager with experience in different plants and different companies.

The Voice of Experience

Extrusion Plant Preventive Maintenance (PM) Program Recommendations

The following is a guideline that can be applied to any equipment in the manufacturing facility but has some examples that focus on the extrusion plant in the sample check list supplied. The guideline is written with the emphasis on a production environment operating 24/7 with one 8 to 12 hour shift per month of scheduled down time for the planned Preventive Maintenance (PM) tasks. The Preventive Maintenance program is only one of the required components that are necessary to reach a high and sustainable *Service Factor*, but is one of the most important parts of a good maintenance program. Every manufacturing facility has to tailor their own program around their own equipment, personnel, and operating environment. This type of PM program will build better employees and at the same time make the manufacturing facility more prosperous if implemented and maintained.

The PM program consists of:

- I. Equipment Daily and Weekly Check Sheets
- II. Equipment Monthly PM Task List
- III. Equipment Semi-Annual PM Task List
- IV. Equipment Yearly Major Maintenance Task List

I. Maintenance Daily Check Sheets

The Daily Check Sheets contain simple checks that are designed to have someone from the maintenance department do a brief scan around the equipment every day while the equipment is in operation. Any assignments listed that are to be carried out while the equipment is in operation should be identified and approval granted by a qualified member of management that the inspections can be done safely. The inspection task should have the following objectives:

- a) **Safety** – In every manufacturing plant, safety has to be the number one concern at all times. No unsafe situation should lie in wait for days or weeks without being noticed. It is most important that any unsafe item such as a missing guard, exposed wires, loose components, etc., be spotted during this inspection so the equipment can be shut down immediately and corrected.
- b) **Problem Identification** - One of the main objectives of the check sheets is to get the employees' eyes and ears into the different areas to spot any difference in the process from day to day. Once they are in the area, everyday minor or abnormal sights and sounds within the process equipment will become obvious. The items that are listed on the daily check sheet should strategically be picked based on how critical the component or area is to the process and to make sure all areas that can be covered safely are observed. Many existing and potential problems can be identified this way. One of the key components in achieving a good Service Factor is spotting problems that could possibly turn into breakdowns.
- c) **Problem Correction** – During the daily inspection minor problems can be noticed and corrected if possible during planned times of the shift. This can eliminate extended

downtime and prevent major problems. Much of the total downtime for the month can be attributed to minor stoppages that at the time are not major problems but are major contributors to the total downtime.

- d) **Problem Documentation** – Some problems that are found during the daily inspection are not deemed practical to correct at the moment but should be documented to have a record of the need to be taken care of during the monthly PM; or if possible the Maintenance and Production departments may plan and schedule minor problems to be corrected during breaks, meeting times, etc. The main objective is to make sure a problem, potential problem, or situation is documented for future correction.
- e) **Experience** – The daily check sheets should be done by different employees on different shifts for a time and then rotated for different processes. This will expose more people to the various processes in the plant and reduce the dependence on any one individual. Cross training should come naturally if these procedures are allowed.
- f) **Communication** – One of the main contributors to excessive downtime is communication, or the lack of it, between the maintenance technician and the production operators. The machine operator is one of the most valuable tools the maintenance department has if used correctly. There must be respectful dialog between these two every day to achieve success.

II. Maintenance Weekly Check Sheets

The Weekly Check Sheets contain items that are not as critical and would require excess time if they were on the Daily Check Sheets. These items should be picked based on the severity of the outcome if there is a failure, available spare parts, time required for change out, etc., and even though they may not be checked every day, they do not need to go an entire month before they are checked. All the same objectives as the daily checks should apply, only the frequency is changed.

III. Monthly Preventive Maintenance Task List

The Monthly PM task list should be designed for duties that generally require planned down time. All tasks that are performed during this time should be items that have been identified as critical areas of the process, that require attention every month, and can not normally be accessed during production time. These tasks should have the following types of work:

- a) **Calibration** – Calibration of sensors and instrumentation today is an important task. Measurement sensors should be checked for integrity and validated for accuracy. The operation of system sensors is responsible for making the processes consistently reliable in all areas including safety, productivity, recovery, information and control parameters. In this information age many decisions are made based on trust in the field devices. It is very important to put together a good calibration PM program for the electrical technicians to carry out.
- b) **Inspection** – Identify critical areas of the equipment that require disassembly so that they can be done during the planned down time. The objective is to identify and repair or replace components that could possibly fail before the next PM day. Even if no work has to be performed, for many of these items their condition should be documented in order to build history so that more is learned about the life or patterns of how the components hold up.
- c) **Alignment** – All equipment failures have a root cause. Many times this root cause is loose or misaligned parts. All areas of a process that operate under critical alignment specifications should be identified and procedures written to carry out these task at this time. Attention that is given to this task will guarantee fewer failures. Examples of areas of alignment are motor/pump combinations, moving assemblies, mounted switches and sensors, cameras, etc.
- d) **Cleaning** – There are always areas of a process that can drastically be influenced by contamination. This can affect the operational life of components, accuracy, and consistency of components as well as the product being produced. Contamination is another major contributor to downtime that is often ignored. It is important that this be taken seriously in order to have a successful operation. Most problems in a hydraulic system are due to contamination.

- e) **Component Replacement** – Components that have been identified to be changed out due to hours of operation or indicators showing near or at replacement should be replaced during the PM. Many companies use good tracking methods by computer or paper and can predict very well the life of a component. At times it can be more economical to replace a component during this time rather than incur an unplanned breakdown.

III.) **Semi-Annual PM Task List**

The Semi-Annual PM task should be items that are identified as jobs that require more time than has been allotted for the monthly PM. Some tasks may include:

- a) **Special Projects** – Special planned enhancements that can boost productivity and recovery and show a good payback for the rest of the year.
- b) **Component Replacement** – Some processes may contain components that require replacement before the end of the year.

IV.) **Yearly Major Maintenance Task**

The yearly major maintenance tasks should include items reserved for a low production time of the year and planned-for tasks that are not emergency items, but take more than one day to complete. However, there are some tasks that may take longer to complete but can't be postponed until the yearly shut down as there would be a risk of more lost production time waiting for this date to arrive. Examples of yearly maintenance jobs:

- a) **Wear and Tear Items** – Certain wear and tear items can last a year or years before replacement. These tasks need to be identified and planned for replacement at this time.
- b) **Special Projects** – New equipment, equipment upgrades and enhancements
- c) **Equipment Rebuilds** – Complete refurbishment for better reliability throughout the year.
- d) **Major Component Replacement** – For some components it is more economical to replace before a failure occurs, but it takes more than a day for replacement.

Conclusion

As can be observed from the detailed information above, the *Daily Check Sheets* are probably the quickest to do but are the most important component of the entire PM process. Most of the daily inspection is used for planning the PM duties and tasks. Most of the small problems that are found and repaired during the daily inspections allow the allotted time of the monthly PM to be used for planned tasks. Once the monthly PM begins and the equipment is shut down and turned over to the maintenance department there is no time for planning or for looking for potential problems that should and could have been accessed during the weekly inspections. Every minute of the monthly PM time is valuable and must be productive. All planning of tasks, employee work schedules, necessary parts, outside resources and services must be accounted for. The objective is to check and certify that the processes are in favorable condition to operate for the next month with a very low probability of failure. The PM time is usually shared between general repair items, special requests and any unplanned problems that are found while working. As the program is developed more and more and the program is continually improved there should be more flexibility to shift blocks of time to different job duties. If used correctly, most of the planned downtime can be made up through a decreased amount of unplanned downtime. Other components that are required to produce a successful maintenance program are:

- continuous training programs
- good organization of critical spare parts
- necessary tools for the job
- good relationships with the rest of the work force, and
- (an absolute) the support from upper management.

The following pages show a few examples of the first part of the program, the *Maintenance Daily Check Sheet* for the maintenance technician. It is not focused on a craft (mechanical or electrical, for example) of the employee, but rather attention to a situation that could arise or a faulty part of the process that needs to be communicated and documented. The example is a

Maintenance Daily Check Sheet for a **SMS Sutton 1800 UST direct extrusion press**. Even if your press is different, it will serve as a guide for you to write your own *Maintenance Daily Check Sheet*. The monthly, semi-annually and major maintenance task lists are more geared to the craft of the technician since they focus on actual job duties. Each part of the program has to be tailored to fit the specific process and its own details. It is also important for the operators to have ownership in the program for the entire program to be successful. Check sheets and PM task should be created through a team effort that focuses on items in which the operators and maintenance technicians have a part.

Following the *Maintenance Daily Check Sheet* on page 1-15 is the *Extrusion Press Troubleshooting Chart*, which explains in more detail the points on the Check Sheet and what action should be taken to resolve each type of problem.

Maintenance Daily Check Sheet Procedure

1.0 Check butt shear for proper cutting.

Check to make sure butt is being cut from die face and not torn away. *If tearing occurs, refer to Sec. 1.0 on Extrusion Press Troubleshooting Chart.*

2.0 Check butt knocker for proper operation.

The butt knocker rod is controlled by a pneumatic cylinder. It should stroke and strike the butt at the end of the shear stroke cycle with high impact and knock the butt away from the butt shear blade. If there is no butt stuck on the blade to absorb the high impact of the knocker rod collar, there is a spring to absorb the load. If a loud clanging noise is heard, the air cylinder mount or coupling could be loose. *Refer to Sec. 1.0 on Extrusion Press Troubleshooting Chart for further information.*

3.0 Monitor the press cycle.

During the press cycle, watch and listen for:

Closing of Container – The container should advanced toward the die without shifting side to side, then slow down just before reaching the die and gently seal flat against the die ring. *If there is side motion of the container housing while opening or closing or if the container is slamming into the die, refer to Sec. 2.0 on the Extrusion Press Troubleshooting Chart.*

Loader Cycle – Once the container is closed, the loader should raise quickly, with a smooth motion and no bounce at the end of the stroke, to accept the billet from the overhead loader. *If loader motion is slow or jerky, refer to Sec. 3.0 on the Extrusion Press Troubleshooting Chart.*

Ram Advance – After the overhead loader has safely cleared from possible interference of the crosshead the main ram should advance rapidly, pushing the billet concentrically into the container without dragging on the side of the container opening. *If slow movement of the main ram occurs, refer to Sec. 4.0 on the Extrusion Press Troubleshooting Chart.*

Dummy Block Entry - Dummy block should enter the container without any top, bottom or side load on the block. *If the ram stem is forced down while entering the container or build up of aluminum on the side of the opening of the container occurs refer to Sec. 4.0 on the Extrusion Press Troubleshooting Chart.*

Upset/Burp Cycle – Main ram should press billet against die, not slam it, into the die, and build pressure. Once the preset upset pressure is reached, the container should open enough to break the seal between the container and die, pushing the ram back with the upset billet and releasing the trapped air in the front of the container. After opening, the container should close and re-seal without slamming. If the container does not open enough to break the seal, the air will not escape and blisters will result. If the container opens more than needed, lost time will result. *Refer to Sec. 2.0 on the Extrusion Press Troubleshooting Chart.*

Extrusion – The press should build required pressure and reach a steady set point speed. The extrusion press is designed for the system to develop a maximum of 3000 PSI of hydraulic pressure on the main ram and side cylinders if required by the load and to reach approximately 44 inches per minute of ram speed. If maximum pressure of 3000 PSI can not be achieved with the main ram

dead headed, refer to the troubleshooting chart. If the maximum ram speed can not be reached or the speed is fluctuating refer to *Sec. 5.0 on the Extrusion Press Troubleshooting Chart*.

End of Extrusion – Upon reaching a desired runout length or butt set point the press should stop extruding and decompress the pressure without excessive hydraulic shock. If extreme shock is heard or if there is a loud noise around the pre-fill valve, *Refer to Sec. 5.0 on the Extrusion Press Troubleshooting Chart*.

Container Strip – After decompression the container should start to open while the dummy block is held against the remaining length of billet to strip the expanded butt away from the container wall. There must be a delay between the container open and the ram return to prevent pulling the butt away from the die face. If both the main ram and the container move at exactly the same time, *Refer to Sec. 4.0 on the Extrusion Press Troubleshooting Chart*.

Container Open/Ram Return – After the container has reached the butt stripped position the ram will return at the same time the container opens. The dummy block should pass through the container without excessive resistance due to buildup inside the container or around the land of the dummy block. The ram should return to the home position and gently coast to a stop avoiding contact between the back of the main ram cylinder and the housing. If slamming occurs, *Refer to Sec. 4.0 on the Extrusion Press Troubleshooting Chart*.

Butt Shear Cycle – Once the dummy block and container are behind the safe-for-shearing point, the butt shear should advance downward shearing the butt clean from the die face until reaching the end of the stroke of the shear cylinder. At the end of shear travel, the pneumatic controlled butt knocker should advance and strike the butt at high impact, dislodging the remaining discard section. As the butt knocker is in operation, the butt shear cylinder should retract and travel to the top (home) position. There should be a small delay when the shear cylinder reaches the down position before returning to prevent hydraulic shock in the system. Once the shear is in the top (retracted) position, the pressure from the main pump(s) is removed and the shear is held in the up position by pilot pressure, preventing the shear assembly from drifting down if there is leakage (internal or external) on the rod side of the cylinder. If there are problems with the operation, *Refer to Sec. 1.0 on the Extrusion Press Troubleshooting Chart*.

4.0 Grease container, press ways, and die slide.

The container housing and crosshead are designed to slide on precision flat hardened steel ways. The load is supported on bronze wear plates (shoes) machined with grease ports to distribute the lubricant across the width of the sliding surface. The grease has to be pumped in manually through grease fittings. If the grease is properly flowing through the channels, the load will be sliding on a thin layer of lubricant. The wipers mounted on each end of the crosshead and container shoes push away any debris on the ways to prevent contamination from entering in between the bronze and hardened steel causing premature wear of the steel ways. The grease should be applied every day.

The die carriers and the drive assembly slide on a bronze wear plate that should be lubricated every day. There are grease lines mounted on the front of the platen to safely apply the grease to the sliding surface. Always use recommended lubricants.

5.0 Check hydraulic oil temperature and record.

Check the press hydraulic oil reservoir temperature and record the reading on the check sheet. The hydraulic oil recommended for this system by the original equipment manufacturer is an ISO 68 and should be run at 100 degrees F to obtain a viscosity of 300 SUS for proper lubrication and system efficiency. If the oil is at a lower temperature the viscosity (resistance to flow) is increased and the system has to work harder and a noticeable slow down of movements of the cylinders and shifting of the valves will result. If the oil becomes too hot, the pumps, seals and the oil itself have limits and damage can result. If the temperature reaches 120 degrees F, start looking for possible heat generation within the hydraulic system or a decrease of heat removal from the cooling source and refer to *Sec. 9.0 on the Extrusion Press Troubleshooting Chart*.

6.0 Check dummy block/ram stem for excessive aluminum build up.

The fixed dummy block is designed to run in the center of the container while expanding very close to the container wall, preventing blow-by or back extruding. Depending on the design of the

fixed block, there should be a certain amount of float to compensate for slight variances in misalignment. If there is too much misalignment between the container and fixed dummy block, excessive build up around the land of the block and on the ram stem can occur. The result can be damage to the dummy block as well as the inner wall of the container liner. The fixed dummy block is generally designed with outside diameter of .035 to .045 in. below the container bore. The geometry is such that the block should expand under pressure to very close to the container wall ID while extruding and collapse back to the designed OD after the pressure has relieved, allowing the dummy block to return through the container without resistance. Over time, the steel of the dummy block can become fatigued and will not collapse, thereby dragging the aluminum that is stuck on the container walls back through. If there is excessive resistance on the main ram while returning through the container, *Refer to Sec. 4.0 on the Extrusion Press Troubleshooting Chart.*

7.0 Check for any high volume or high pressure oil leaks.

Check hydraulic cylinders (main ram, pull back, butt shear, die slide and shifting) for leaking oil at the rod gland packing. There should only be a minimum layer of oil on the cylinder rod for proper lubrication. Check oil lines for leaks at fittings and check for small cracks in the oil pipes. If leaks are found that are excessive, shut down the press as soon as possible and lockout and repair. For small leaks, tag the device that is leaking and prepare to fix it at the next scheduled PM.

8.0 Check container for proper sealing operation.

The main pumps will drive the container closed. Upon engaging the die ring, the container closed limit switch should make, allowing the sealing pump to pressurize the container shifting cylinders on the rod end and form a tight seal between the container liner face and the die ring. If there is heavy build up on the face of the liner or the die, this may result in an insufficient seal and extrusion between the liner and die can occur (flare outs). This area can see the same pressures as the die face, and the aluminum will flow through the path of least resistance. If excessive build up occurs in one area (mainly on the bottom due to bad shearing) the container will tilt forward while sealing. This press is designed with the loader attached to the container, so if the container tilts, the loader will raise substantially causing interference between the loader cradle and the fixed dummy block. The container shifting cylinders will attempt to pull the container flat against the die ring. If the housing is low in the back (ram side) the container will tilt forward raising the loader also. If the container is high in the back, the result will be excessive pressure on the die carrier guides resulting in damage to the wear plates. When the container is sealing, look for any of these conditions. *Refer to Sec. 2.0 on the Extrusion Press Troubleshooting Chart.*

9.0 Check die hold down bar for damage or looseness.

The hold down bar is designed to prevent the die stack tooling from being lifted during the operation of the butt shear cycle on the up or return stroke. Check to make sure there is not enough clearance between the top of the tooling and the die hold down bar for the tooling to be picked up more than the height of the key stock at the bottom of the tooling. Also, make sure there is enough clearance for the top of the tooling to traverse back and forth on the die slide without interfering with the hold down bar. If the die appears to be lifting or rotating, *Refer to Sec. 1.0 on the Extrusion Press Troubleshooting Chart.*

10.0 Check with the operator for any equipment or operational problems.

The operator is around the equipment most of the shift and can easily recognize conditions as they change. Ask the operator if he or she has noticed anything unusual or abnormal with the operation of the press. Make notes in the comment section so a work request can be generated.

11.0 Check the burp cycle for correct operation.

The function of the burp cycle is to expel any entrapped air between the front section of the container and the die, preventing air bubbles and blisters forming in the extrusion. In order for the air to be pushed toward the front of the container, the cycle has to go through the upset cycle deforming the billet to the container wall, pushing the air to the front and back. Most of the air that is pushed to the back of the container (ram side) while the billet and dummy block are entering the container should escape around the dummy block unless there is excessive build up on the container liner or dummy block land or both. The operation of this cycle should be:

1. container closes and builds sealing pressure

2. main ram pushes the billet against die face building enough pressure to conform the billet to the inside diameter of the container but not enough to extrude through the die
3. decompress the main ram pressure
4. open the container, pushing the main ram back with the upset billet just enough to release the entrapped air
5. close the container and build sealing pressure

This all should be done quickly with minimum shock. If the sequence is not correct, *Refer to Sec. 2.0 on the Extrusion Press Troubleshooting Chart.*

12.0 Check crosshead and container jamb nuts for looseness.

The container housing has adjustment studs for elevation alignment. Above the main top nuts, there are thinner nuts used to prevent the adjustment from changing during operation. Make sure these nuts are tight at all times. The same applies to the crosshead adjustment studs.

13.0 Check loader for proper operation and alignment.

The loader raises to receive the billet from the overhead loader and lowers to clear itself from the crosshead after the billet has safely traveled far enough into the container. The movements should be fast and smooth without shock or bounce. The loader contains a cradle for guiding the billet into the container. The cradle bars should be adjusted so that the back (ram side) is low enough to prevent interference of the float of the dummy block and high enough on the container side to prevent the billet from dragging on the edge of the container.

Top Of Press

14.0 Check motors and pumps for any unusual sounds or vibration while running.

Become familiar with how the pumps and motors sound and react under normal, non-malfunctioning operation. Check every day for any abnormal sounds, vibration or heat build up from the press pumps and motors. Note in the comments section anything that is found so further investigation can be done.

15.0 Check press pit for hydraulic oil.

Any hydraulic oil in the press pit should be pumped out. The hydraulic oil is combustible and can produce enough heat if ignited to destroy the press and endanger others.

16.0 Check and record the auxiliary pressure.

Pump PF3 is used to supply hydraulic oil to move the rotostation die changer, loader and surge (pre-fill) valve and to assist the main ram travel during ram return. Check the setting of the relief valve by observing the pressure reading on the gauge. The pressure should be at least 500 but no more than 600 PSI. Record the pressure on the check sheet to verify proper system pressures. If the pressure is low, *Refer to Sec. 8.0 on the Extrusion Press Troubleshooting Chart.*

17.0 Check and record the pilot pressure.

Pump PF3A is used to supply hydraulic oil to shift the larger spool valves in the system and to provide pressure to hold up the butt shear. Check the setting of the relief valve by observing the pressure reading on the gauge when this pump is loaded. The pressure should be at least 150 PSI. Record the pressure on the check sheet to verify proper system pressures. If the pressure is low, *Refer to Sec. 8.0 on the Extrusion Press Troubleshooting Chart.*

18.0 Check and record the servo pressure.

Pump PF4A is used for one function only. It is used to supply hydraulic oil to the main pump servo valves for controlling the stroke of the main pumps. Check the setting of the relief valve by observing the pressure reading on the gauge. The pressure should be at least 500 PSI and no more than 600 PSI. Record the pressure setting on the check sheet to verify proper system pressures. If the pressure is low or if the pressure has extreme swings when the pumps stroke, *Refer to Sec. 8.0 on the Extrusion Press Troubleshooting Chart.*

Press #5 - Extrusion Press		Date:
Maintenance Daily Check Sheet		Mechanic:
Item #	Description	Time Used:
1.0	Check the butt shear for proper cutting.	
2.0	Check butt knocker for proper operation.	
3.0	Monitor two cycles of operation and note any abnormal condition.	
4.0	Grease container, press, and die slide ways.	
5.0	Check hydraulic oil temperature and record. Oil Temp. ° F (If the temperature is over 125° F look for the problem.)	
6.0	Check dummy block/ram stem for excessive aluminum build up.	
7.0	Check for any high volume or high pressure oil leaks. (Shut down and repair if excessive, tag for later repair if minor.)	
8.0	Check container for proper sealing operation.	
9.0	Check hold down bar for damage or looseness.	
10.0	Check with operator for any equipment or operational problems and note in comments below.	
11.0	Check the burp cycle for correct operation. (Container should only break seal to release entrapped air.)	
12.0	Check container and crosshead jam nuts for looseness.	
13.0	Check loader for proper operation and alignment.	
14.0	Check motors and pumps for any unusual sounds or vibration while running, note if found.	
15.0	Check press pit for hydraulic oil. (Pump out oil if excessive.) (Fire Hazard)	
16.0	Check and record the auxiliary pressure. PSI (Should be minimum 500 PSI)	
17.0	Check and record the pilot pressure. PSI (Should be minimum 150 PSI)	
18.0	Check and record the servo pressure. PSI (Should be minimum 550 PSI)	
Notes:		
All of the checks can be performed with the system running. If attention is needed, shut down the equipment. Always lockout equipment to make adjustments or repairs if required. List any abnormal conditions of the equipment operation or safety concerns in the comment section.		
Comments:		
		REV 1.5 3/29/2004

See Daily Check Procedure for Further Information

Extrusion Press Troubleshooting Chart			
Item	Problem	Causes	Possible Solutions
1.0	Butt Shear Operation		
1.1	Improper butt shear cut	Excessive clearance between blade and die face	Check clearance with a feeler gauge between blade and hot tool stack. The clearance should be between .005" and .010" (0.12 - 2.5 mm)
		Loose bolts	Check to make sure the butt shear blade bolts are tight.
		Excess clearance between tool stack and die slide/carrier saddle ring.	Check for wear on retaining ring. Repair or replace.
			Check for excessive wear on die slide wear plates. Replace.
			Check for worn or damaged cutting surface on blade. Replace if necessary.
1.2	Butt shear blade reaches the butt and will not cut	No assistance from main pumps.	Check to make sure all pumps are on and operating. See note 1
		The hydraulic circuit of the shear is still in the regeneration cycle	Check the limit switch for changing the circuit from speed to power for improper position. See Note 2.
1.3	Butt shear slams on return stroke	Return slow limit switch not working properly	Adjust limit switch position
		Cylinder cushion not working	Adjust cylinder dampening screw.
1.4	Butt sticks to blade and won't release.	Lubrication equipment not working properly.	Check to make sure system is spraying lubricant on the blade. See Note 3.
		Excessive aluminum build up on blade	Change blade
		Butt knocker not functioning properly	Check air pressure setting
			Check mounting bolts for looseness
1.5	Butt knocker not extending	Incorrect air pressure	Check air pressure at directional valve for proper pressure
		Loose mounting bolts, binding	Tighten, Replace if missing
		Bent knocker rod	Replace knocker rod.
1.6	Butt shear lifts tool stack on return stroke.	Missing or damaged hold down bar	Repair or replace. See Note 6
1.7	The die or tool stack rotates during the shear cycle	Missing key stock	Replace key stock

Extrusion Press Troubleshooting Chart			
2.0	Container Operation		
2.1	Container will not close	Interference from butt shear	Check to make sure butt shear is in the full up position and the butt shear up limit switch is made.
		Tilt Switch	Check to make sure the container is not tilting off the tilt limit switch
2.2	Container will not open	Program out of sequence	Check program logic
		At the end of the extrusion cycle with a weld pocket or feeder plate die the butt length may be to long	Continue extrusion if possible to the maximum butt length.
2.3	Container moves side to side when closing or opening	Excessive clearance at the container guide	Adjust or replace rear plates if there is no adjustment
		Excessive clearance between shifting cylinder nuts and container housing.	Adjust to proper clearance and correct distance between front nuts and platen.
2.4	Container slams against die face	Pump controls need calibration	Check calibration between pump stroke command and pump stroke position feedback position
		Oil temperature high (Low oil viscosity)	Check cooling system for proper operation
			Check for excessive heat build up in hydraulic system
		Limit switch or position sensor problem	Check slow down limit switch for looseness of switch or switch arm or position transducer.
2.5	Burp cycle does not initiate.	Burp cycle selector in off position	Switch selector switch to on position
		Burp cycle selected for no burp on first billet	This is OK unless die is already filled with aluminum
2.6	Burp cycle initiate but container never actually moves.	Shifting cylinder nuts have too much clearance	Set shifting cylinder nuts to proper clearance between face of nut and container housing. See Container Alignment Procedure.
		Container limit switch position	Adjust container closed limit switch for proper operation.
		Container open timer	Timer open preset value may be too low for oil temperature.
		Oil temperature low	Check cooling system for proper operation

Extrusion Press Troubleshooting Chart			
2.7	Container opens too much during the burp cycle	Oil temperature high	Check cooling system for proper operation
		Container open timer	Timer open preset value may be too high for oil temperature.
2.8	During strip cycle the container and ram move at the same time.	Ram return limit switch making prematurely	Adjust limit switch arm.
		Ram position transducer feedback signal incorrect	Calibrate sensor.
2.9	The container closes but does not have any sealing pressure	Container closed limit switch is not made	Check container closed limit switch for proper operation
		Sealing pump not in operation	Check and make sure sealing pump is turned on and operating
		Sealing pump load valve not functioning	Check to make sure the load valve is energized and has shifted
		Container tilted	Check for build up on the bottom of the face of the container liner or the die or die ring.
2.10	The container closes and builds pressure but is low	Pressure does not build at pump with pump running	Check pump compensator for proper adjustment - See pump operation manual for adjustment procedure.
			Check backup relief valve for internal leakage
			Check shifting cylinders for leakage around cylinder pistons. See Note 4:
2.11	The container builds pressure after the ram builds pressure	Container closed limit switch out of adjustment	Change the position at which the switch makes during container close. See Note 5
		System leakage is high	Find source of leakage and repair
3.0	Billet Loader Operation		
3.1	Billet loader will not raise	Ram position not in safe position	Check main ram position for clear; Check ram position for proper feedback position
		Hydraulic control problem	Check hydraulic auxiliary circuit for proper pressure
3.1	Billet loader has jerky motion	Hydraulic control problem	Check hydraulic circuit feeding loader for proper pressure
		Mechanical looseness	Check loader pivot bushing for excessive wear. Replace if necessary.

Extrusion Press Troubleshooting Chart			
4.0	Main Ram		
4.1	Main ram will not advance	Die slide position	Check to make sure the die slide in a safe position and the slide position limit switch is made.
		Loader check position	Check to make sure loader is in the clear position
		Butt shear position	Make sure the butt shear is in the up position and the limit switch is made
4.2	Main ram will not return	Press sequence is out of cycle	Check program logic
4.3	Main Ram Advancing Slow	Pump controls need calibration	Check calibration between pump stroke command and pump stroke position feedback position
		Press cycle out of sequence	Check program for improper conditions.
4.4	Stem/Dummy Block Loading	Container/Ram Alignment	Check container to stem alignment. Adjust if necessary.
		Build up on entrance of container	Check for proper loader to stem/container alignment.
4.5	Main Ram slamming on return stroke	Ram position transducer feedback signal incorrect	Calibrate sensor.
		Incorrect pump stroke command	Check program for correct preset value
4.6	Main Ram retracts at the same time the container opens after the end of the extrusion cycle.	Butt stripped limit switch making prematurely	Adjust limit switch position
		Container open speed higher than ram return speed	Look for cause of slow ram return speed.
5.0	Extrusion Cycle		
5.1	Maximum extrusion pressure cannot be reached	System Relief valve by passing	Check for contamination in valve or worn parts. Clean or replace if needed
			Check for proper pressure setting. Adjust if necessary.
5.2	Maximum extrusion pressure is too high	Pressure transducer incorrect	Check calibration of system electronic pressure transducer. See System Pressure Transducer Calibration.
		Pump controls need calibration	Check calibration between pump stroke command and pump stroke position feedback position

Extrusion Press Troubleshooting Chart			
5.3	Preset extrusion speed cannot be reached	Pump controls need calibration	Check calibration between pump stroke command and pump stroke position feedback position
		Pumps not on line	Check to make sure all pumps are on and operating.
		Internal leakage	Check hydraulic system for heat build up to find leakage.
5.4	Runaway extrusion speed	Ram position transducer feedback incorrect	Check for missing speed signal
		Loss of main pump stroke feed back signal	Check for feedback signal at pump amplifier card.
5.5	Shock at the end of the extrusion cycle	Decompression of cylinder too fast	If adjustable, decrease. If not, ramp speed down at the end of the extrusion cycle
5.6	Loud noise around the pre-fill valve at the end of the extrusion cycle	Prefill valve opening too soon	Check program for correct pressure setting.
			Check pressure transducer for proper feedback.
			Check dampening controls on prefill valve for proper adjustment.
5.7	Ram slams into billet when loading	Ram position transducer feedback incorrect	Check calibration of ram position transducer. See Ram Position Calibration Procedure.
5.8	Incorrect butt size	Ram position transducer feedback incorrect	Check calibration of ram position transducer. See Ram Position Calibration Procedure.
6.0	Die Change Cycle		
6.1	Auto die change cycle will not initiate	Process out of sequence	Check conditions in program
6.2	Die slide will not move	Main ram not at safe position	Check the position of main ram: Check position feedback
7.0	Pumps and Motors		
7.1	Main pump motors will not start	Auxiliary pump off	Start auxiliary pump first
		E-Stop engaged	Locate the E-Stop that has the control circuit locked out
		Motor overload tripped	Investigate overload cause and reset
		Main line fuses blown	Investigate over-current cause then replace fuses
		Disconnect off	Investigate reason (Should be locked out if off)

Extrusion Press Troubleshooting Chart			
7.2	Main pumps will not stroke	No servo pressure from auxiliary pump	Check pressure at servo relief valve
		No command from amplifier card to servo valve	See Servo System Troubleshooting Chart
		Flow control valves to servo valves shut off	Turn on
7.3	Main pumps stroke slow	Oil flow restriction to servo system	See Servo System Troubleshooting Chart
		Low servo pressure from auxiliary pump (PF4A)	Check pressure at servo relief valve
7.4	Pumps stroke but can not build pressure	Load valve Z1 or Z2 not energized	Check program for conditions.
8.0	Auxiliary Pumps		
8.1	Motor for auxiliary pump will not start	E-Stop engaged	Locate the E-Stop that has the control circuit locked out
		Hydraulic oil high temperature switch made	Refer to Section 9.0
		Motor overload tripped	Investigate overload cause and reset
		Main line fuses blown	Investigate over-current cause then replace fuses
		Disconnect off	Investigate reason (Should be locked out if off)
8.2	Auxiliary pump (PF4A) has low pressure	Relief valve bypassing	Clean or repair valve
		No volume from pump	Repair or replace pump
8.3	Auxiliary pump (PF3A) has low pressure	Relief valve bypassing	Clean or repair valve
		No volume from pump	Repair or replace pump
8.4	Auxiliary pump (PF3) has low pressure	Relief valve bypassing	Clean or repair valve
		No volume from pump	Repair or replace pump
9.0	Cooling System		
9.1	System hydraulic oil temperature is high	No oil flow through heat exchanger	Pump (PF4) is bad. Repair or replace
			Heat exchanger is clogged on water side. Check pressure in and pressure out. Clean if high differential pressure.
		No water flow through heat exchanger	Check water pump from cooling tower.
			Heat exchanger is clogged on water side. Check pressure in and pressure out. Clean if high differential pressure and temperature.
		Excess heat generation in hydraulic system	Check for areas of high heat around cylinder pistons and relief valves.

Extrusion Press Troubleshooting Chart			
9.1	System hydraulic oil temperature is low while running	Too much water flow	Decrease water flow

Note 1:

If the butt shear cylinder is enabled to stroke down and no oil is supplied, the shear will drop to the butt from its own weight and no cutting will occur.

Note 2:

If the shear blade comes in contact with the butt before the limit switch makes, no power is available for cutting.

Note 3:

Never allow the butt shear lubricant to be applied when the container is open to avoid contamination on the face of the die and inside the container liner.

Note 4:

Check temperature of the cap end of the cylinder vs. the rod end. If oil is blowing by the piston rings at high pressure there will be considerable heat difference.

Note 5:

The sealing pump is a very low volume high pressure pump. The container must be closed with the main pumps so that the cylinders are completely filled with oil so the sealing pump only has to pressurize the cylinders.

Note 6:

The hold down bar should not allow the tool stack to be lifted up more than the height of the key that extends into the bottom key way of the tool stack.

The next pages offer some helpful recommendations by Mr. P. Gopalan Kutty an experienced Extrusion Maintenance Manager. We hope readers will find these recommendations useful and will likewise share their ideas and experiences for future editions of this Manual.

The Voice of Experience

Extrusion Press - Maintenance – A Predictive Approach

The Aluminum Extrusion industry is a fast developing industry, and as a result the whole approach to performance and maintenance is also changing. Gone are the days when one was happy with a 15 second dead cycle and a 5% breakdown percentage. The modern presses with high-tech hydraulics and PLC's are capable of running at 10 seconds and consume a lot less energy and manpower. Front loading, short stroke, longer billet lengths, double pullers and longer run out all contribute to better performance and recovery.

In earlier days, a good lubrication program, periodic alignment checks, routine check on wear parts and a good filtration system were the foundations for a maintenance program. With the development of PLC controls the first big steps in improvement started. Not only did they eliminate all moving electrical contacts but they also shaved seconds from each operation. This resulted in the need for better hydraulic components with proportional controls that complemented the PLC controls. With the advent of modern hydraulics the need to keep the oil cleaner became all too obvious.

So, extrusion as a whole evolved to a faster, more efficient and high tech operation.

The advent of management information systems interfacing with PLCs opened a whole new world in performance analysis.

Where does that leave a maintenance man, and what options does he have available to do his job better? What are the new tools available for a maintenance professional?

Tools of the past:

- Manual Lubrication
- Torque and tightness checks
- Ultrasonic inspections
- Alignment checks using optical telescope (transit)
- Weld inspections
- Hydraulic oil analysis

Tools of the present:

- Sensors to monitor wear, alignment, central lubrication
- Encoders to measure accuracy
- Wear indicators and position indicators
- Infrared thermography
- Particle counting and oil purity

Tools of the future:

- Wireless monitoring
- Internet

The terms *predictive* and *proactive* are used widely, but how does one find modern tools to justify them? Prediction is always based on past performance and parameters against the present ones to indicate future trends.

Structural Inspections. Even though hydraulics and controls and certain innovative designs have changed over the years, the heart of an extrusion press is still a sound mechanical structure. A time-based program for crack detection by magnetic particle or ultrasonic flaw detection techniques on

major welds will give you an indication of the soundness of press components such as columns, main cylinder and container.

Alignment Checks. A periodic alignment check on the press will give an indication of wear and tear on bushings and other moving parts.

Information Technology. This is one area where things have changed by leaps and bounds. Management information systems and Process information systems play an integral part in maintenance.

Management information systems are real time material tracking and data acquisition systems which help the maintenance staff not only to monitor but to take critical decisions on important equipment.

Process information and control systems are man-machine interfaces that enable the operator to monitor and optimize the production and to quickly find the error causes or malfunctions. They show:

- current machine data
- status data for the maintenance staff
- display and print out of alarm and alarm history
- diagnostic text
- all production input data

Both of these applications track material and machine status in real time in a Windows-based application.

Every aspect of the Extrusion operation from Die to Dummy block dimensions is recorded and tracked.

From the Maintenance point of view, graphic representation of the performance of pumps, container heating, oil temperature and pressure will give a true indication of the performance of the components.

Predictive maintenance depends a lot on performance characteristics and the features help in planning a maintenance activity on major press controls. Since it is linked to the PLC the alarm history analysis and status history are two other tools for Maintenance personnel.

Using Wireless Technology and the Internet for Predictive Maintenance

Wireless, Point-to-Point Communication System. The wireless ethernet link between a monitoring system on an industrial machine can transmit data to an end user PC. This opens a whole world of Maintenance possibilities. For example, vibration sensors send the data and the end user can monitor them as real time gauges.

The success of the future Maintenance Department will depend a lot on their ability to use these modern tools for monitoring and thus predicting failures well in advance.

The Millennium Maintenance Team

A good Maintenance team will need employees with a balanced blend of electrical, electronic, PLC and computer skills.

The Engineer or Maintenance technician can not only monitor but even predict failure of the system or components from a far away place.

So the approach to maintenance is changing and to survive one needs to be able to process the huge data available and to make use of them as a tool for maintenance.

EXTRUSION PRESSES: Routine Inspection of Major Structural Components

1. Columns

- a. It is recommended that approximately once each month a check be made to ensure that all column nuts are tight and there is no undue movement when under load. It is most important that the nuts have uniform tightness; otherwise the columns will carry uneven loads.
- b. It is recommended that the columns be ultrasonically examined at least once every 12 months to ensure that no internal defects exist. Particular attention should be paid to the area adjacent to the threaded portion at the ends of the column. It is advisable that the ultrasonic examination be made when the columns are loaded, since this gives greater accuracy in recording slight changes in condition.
- c. Should the ultrasonic examination reveal any defective areas, the frequency of examination should be increased so that changes in the defect size can be monitored. It is recommended whenever a defect is located in a column, immediate consideration should be given to replacement. Decision on the speed of replacement must take account of the size and growth rate of the defect.

2. Welded Main Cylinder

- a. It is recommended at intervals not exceeding 6 months, an inspection be made of the welds connecting the housing plates to the cylinder body. Particular attention should be given to the circumferential weld nearest to the filling valve end.
- b. The recommended method of testing is the magnetic particle technique: many press users prefer the dye-penetrant method, but this is sometimes difficult to interpret if the weld profile is not smooth.
- c. The type of defect most likely to be exposed by a routine inspection procedure is a small crack in the main cylinder body immediately adjacent to the weld metal. If such a defect is discovered, this should be ground out immediately to remove all of the defect. It is strongly recommended the repair procedure be discussed and agreed with the press manufacturer if possible.

Optical Alignment of the Extrusion Press

Prior to optical alignment it is advisable, in order to ensure a speedy return to normal production, to carry out the following procedure:

1. Switch off container heating immediately after production ceases, leaving the container in the fully unsealed position. If possible arrange an "air blast" to expedite cooling.
2. Remove all tooling, i.e., dies, bolsters, pressure pads and thrust rod.
3. If the container is to be aligned, ensure that the bore is clean and smooth ready to accept a target holder.
4. Remove the lead-out table, quenching system or other handling equipment directly attached to the front platen housing to enable the telescope to be mounted on the outside of the platen.
5. Fix the illuminated target holder and target on the stem holder with an adaptor.
6. Take an initial reading at the start of the travel.
7. Take the second reading at the middle of the travel.
8. Take the final reading at the end of the travel.
9. Note the deviation or dip of the main ram.
10. Allowed dip is 0.012" or 1/1000 of a foot for a 16 MN 3-column press.

Preventive Maintenance - a More Sophisticated Look

To set a PM program in motion is not very difficult but to measure its effectiveness is more difficult. If after doing routine preventive maintenance you still notice that your press is delivering a low performance in terms of dead cycle, then it is time to sit up and do something about it. The term optimization is significant and should be incorporated in the press maintenance schedule on a periodic time interval of at least once in two years or depending on the performance.

Performance Optimization. PO is of high value and is based on the periodical measurement of press dead cycle. The first indication of a press having a problem is usually obtained from the dead cycle time. If one notices a significant change then the problem comes in finding out from where exactly this is originating, and this can be done by a dead cycle analysis.

A list press of operations depending on the particular design of press is tabulated the time for each operation is noted.

TIME							
Pressure release							
Stripping							
Ram backward							
Container open							
Shear Down							
Shear up							
Container close							
Loader in							
Ram forward							
Loader out							
Upsetting							
Release							
Container open							
Container close							
Upset							

After recording these times for each part of the cycle, dead time is calculated 'as is' and compared to the value when the press was first commissioned. If there is a set of readings available from the time of the last tuning or commissioning then the task of the PM tuning team becomes easier.

Once the operation cycle is plotted an idea of time lapse can be identified. A hydraulic circuit diagram with a valve sequence chart is used for further identifying the defect. The circuit usually indicates the speed and the cross sectional area of each cylinder. Before going for sophisticated measuring instruments one can use the ram movement indicator on the press by following this simple procedure:

- Select a particular operation, for example Main ram backward.
- From the valve sequence chart identify the particular valve or valves in operation.
- Identify the pump and the percentage of delivery for this operation.
- Note down the designed pump delivery.
- Mark out a particular length on the ram movement.
- Time the distance marked.

Example: Let us say for a main ram backward operation you need pump number one delivering one hundred percent to obtain a speed of 28 mm /sec.

The actual measurement indicated the speed as 24mm/sec and this shows that either the pump is not delivering the required oil for that operation or hydraulics are at fault.

By applying the formula $Q = A \times V$ where Q is the quantity of oil (in this case the actual pump output), A the area of the cross section of the ram from the hydraulic circuit and V the measured speed, the pump performance can be obtained. By comparing this to the designed output the actual performance of the pump is evaluated.

Most of the pumps have indicators for the degree of operation, from which one can come to a conclusion about the pump delivery status.

From this data it is possible to conclude that either the pump is not delivering the required quantity of oil for the operation or there is something wrong with the related valves.

This is just to give an idea about the methodology and there are many providers who specialize in fine tuning the press. A lot can be done with effort and innovation before calling the experts.

Thermal Alignment. Mechanical alignment of the press is something everyone knows and does on a periodic cycle, but the term thermal alignment is a new term which few of the extruders carry out to improve their productivity, die life and quality.

The process of monitoring and controlling the thermal conditions of the profile, billet, die and container can be defined as thermal alignment. Basically isothermal extrusion can succeed only if you have the proper control of these factors.

Single cell die ovens, multi-zone heating in containers, highly accurate taper heating of billets, and provisions to measure the exact temperature of the billet before feeding to the press, either by thermocouples or non-contact pyrometers, are all important to achieve this thermal alignment.

Exit temperature directly affects the extrusion speed, and any variation in any of these factors will decrease the extrusion speed and any advantage of isothermal extrusion will be lost.

Older Aluminum Extrusion Presses - a Second Chance?

When do you declare a press as 'old'? Is it when you see:

Leaking hydraulics and components? Out-dated energy guzzling pumps? Relay logic and loose dummy blocks? Weld scars on the main housing? A dead cycle of thirty seconds?

Is the old veteran ready to say a sad good bye? Some cry that it is high time you dump it to the scrap heap, or is there something one can do upgrade it? Over the years one often hears this comment among extruders.

The question here is: Is it possible to extract more out of an aging press? Is it possible to modernize it? The answer to the question can be very tricky. If you say 'Yes and 'No' then you are like a good politician. But this is Engineering and not politics and one should be able to give a positive reply. The purpose of this paper is to explore the possibilities and pit falls in modernizing.

Aluminum extrusion presses over the years have evolved dramatically. Gone are the days when you were happy with a fifteen second dead cycle time and a break down time of 5 percent.

Engineering designs and modifications rest on four main pillars:

- Engineering economics
- Actual engineering itself
- Management commitment
- People psychology

Engineering Economics. Simply put it means whether the benefit is worth the expense. Many projects are undertaken without going deeply into the aftermath of the new addition or modification.

A case example here is that of a standard Extrusion press with a shearing problem. The introduction of a modern shear with butt knocker was very attractive and effective. Unfortunately the added thickness of the shear housing to accommodate the butt knocker was not taken into account. As a result the container position and hence the billet length had to be modified. This resulted in a

reduction of the billet by 20 mm and one can imagine the substantial loss in production over the years.

This is just to stress the need to conduct a deep study before venturing forth into the world of modernization.

Venders flaunt brilliant performance of their systems but one needs to study not only the performance of the press but the related ancillary equipment, too.

The initial study should start from the types of profiles and the economical billet length and run out. These to a large extent improve the recovery.

The best way is to make a check list with all the positive and negative aspects of modernizing. Let us start with the Press itself. What are the possibilities and what are the criteria required?

A sound Mechanical structure is important. One needs to look at the heart of the mechanical structure: columns, main housing, platen and end housing, condition of the cylinders. If any of the above shows either wear or even small cracks or damage, the possibility of either replacing or repairing must be taken into account.

Once you have the basic sound mechanical structure the next step is to assess the present condition of pumps, hydraulics and controls. All these can be upgraded for better performance but a study will throw light to the nature of challenge one is in for.

While doing this it is good to look into the existing documentation and circuits. As is often the case with many presses, when some kind of modification or addition takes place, few take the trouble to upgrade the documentation accordingly. A look at the existing inventory is recommended to know if there are any major parts lying in stock over the years and the present stock value.

It is essential that a flow/performance diagram of the performance of the press is mapped to get a clear vision of the performance of various press components.

The next logical step is to investigate the likelihood of bottle necks that can limit the press output even if its performance is upgraded. A billet heater that fails to deliver on time, a puller that has a longer dead time, length of the run out, all come into focus here.

Even with poor performing or outdated ancillary equipment one has the possibility of getting better output from an older press. In such cases the 40% rule of thumb will be of help. If the cost of modification falls below 40% of a new one, the prospect of getting much better return of investment is very bright indeed.

Conclusion

The best method is to evaluate older presses, and most of them have the potential to improve their performance substantially with the right approach. Once the decision is made, there are many Engineering service providers who can design an efficient system tailor-made to suit based on client need. So it is always advisable to explore all avenues before condemning a press to the scrap heap.

Written by: **P. Gopalan Kutty**

Maintenance Manager, Gulf Extrusions, Dubai

Editor's Note: The following information is taken from a Farrel training course manual, circa 1968. The training course was offered to all new owners of Farrel extrusion presses. This information is both interesting and useful, for users of older as well as modern presses, for Farrel and other makes.

Farrel

Extrusion Press Operation and Maintenance Training Course

Press Installation

I. Preparation of the Site

Consideration should be taken when locating a press in your plant. The press should be positioned for convenience of feeding raw material to the press, handling of finished product from the press, die handling, and press maintenance.

Lifting capacity should be adequate for installing dies and removal of press components for maintenance or replacement.

Allow sufficient room around electrical control panels for maintenance. Some panels are attached to the press proper. Some panels are set on the floor away from the press. In either case, allow room to swing the panel doors open for ease of maintenance.

Press components such as tie rods, motors and pumps may require additional space for removal when performing maintenance. Check with the press builder to determine if any components require additional space beyond the general press area.

A. Foundation

When the proposed location of the press has been selected, a load bearing test of the soil should be taken to determine the type of sub-foundation needed. Farrel will furnish a certified foundation layout print showing the bolt locations, loading on specific points, water and air piping, and conduit to be installed in the foundation. It is the customer's responsibility to prepare the site, pour the foundation, and prepare it to receive the base. All foundation bolts should be installed in pipe sleeves to allow for shifting and squaring of the base. Also a drain should be installed in the lowest part of the foundation to drain off oil and water seepage. Local codes should be checked.

The press foundation must be designed to support the weight of the press. You will not be able to maintain press level and alignment if the foundation sags or drops. An out of level condition could induce a twist in the press bed and cause over-stressing of the press components.

B. Conduit

Farrel supplies on the certified foundation print, or on a separate conduit schedule, all conduit sizes, stubbing locations and the number and size of wires to be drawn into each conduit. The purchaser has the choice of either embedding this conduit in the foundation or running it overhead, whichever method suits the individual installation. While the Farrel drawing spells out the conduits and wires therein, it is specifically the responsibility of the purchaser to install the conduit and wires unless their specific contract with Farrel calls for this installation or any part thereof.

C. Water

The certified foundation prints show the location at which the water supply to, and the drain from, the cooler should be installed. As in the case of the conduit, the customer has the prerogative of installing these

lines with the foundation or overhead. The final connections from these lines to the cooler are the responsibility of the purchaser unless otherwise specified in the individual contract.

D. Air

The necessary air supply lines are shown on the certified foundation print. While all the necessary air control piping is done during assembly of the press in the Farrel plant, it is the responsibility of the customer to supply a minimum of 4-5 cu. ft./minute of clean, dry air at 80 PSI. The final connection from this supply to the prefabricated air system is the responsibility of the purchaser unless otherwise specified in the individual contract.

II. Receiving of the Press

A. Inspection

When the press is received, a thorough inspection of all skids, crates, boxes and other type packages, plus any individual pipe or parts not packaged, should be made. If there is any sign of the load having shifted during transport, or any sign of tampering or shortage, an immediate report should be made to the responsible transportation company and to the office of Farrel in Rochester, New York.

NOTE: Pictures should be taken and an inspection made by the transportation company's representative before unloading.

B. Unloading

When unloading, care should be taken that all lifts are made in such a way as not to place undue strain on any components of the equipment. During the unloading, all parts of the shipment should be carefully checked against the packing list. Any shortage noted should be referred immediately to the Rochester, New York office of Farrel Company.

If care is not taken during this time, components of the press frame or piping can be bent, causing at a minimum a delay in start-up and can result in the necessity for re-piping or replacing of components causing a major delay in start-up.

III. Installation

A. Setting on Foundation

Farrel Extrusion Presses are shipped in one of two ways:

1. When possible, taking into consideration the size of the press and the area to which it is being shipped, the entire main press frame and base are shipped in one unit. When this is done, the press is pre-stressed during assembly and not dismantled. The only components removed are the tank, die slide cylinder, shear cylinder and interconnecting pipe.

When the press is shipped in this method, the following is the proper procedure for installation of the press.

The pre-stressed press frame and the base should be either lifted to a position over the foundation bolts and slowly lowered over the bolts onto shims which have previously been placed on the foundation and leveled with a transit; or rolled into position on cribbing, then slowly jacked down, maintaining level as much as possible. The jacking should be done alternately from end to end.

The press is now ready for final leveling and squaring before installation of sub-assemblies.

2. When the size of the press dictates, or the handling facilities at the receiving end are light, the press is dismantled more completely, but never further than necessary to stay within shipping regulations or the lifting capacity of the receiving equipment.

When the press is shipped in this method, the base only, or the base with any components left attached, should be treated the same as the full press frame described below in "B".

During the waiting period and rechecks of the base, the other components of the press can be installed until the press proper is completely reassembled and a final leveling check made.

B. Alignment of Press Base

Particular attention should be paid to the condition of all shims to be inserted under the base and to the placement of these shims. All shims should be at least 3" wide and, depending on the press size, long enough to extend fully under the main side members of the base. A stack of shims must be placed on each side of every hold-down bolt to eliminate the possibility of springing the base. Each shim stack should be a minimum of 1-1/2" high to allow for full floatation of grout. Before inserting any shim, care must be taken that no burrs from cutting remain on the shims, as this will cause incomplete support. See the illustration showing proper placement of shims.

Leveling of the press base should be done with the utmost care. Not more than .0005 of an inch per foot deviation should be allowed. When the press is shipped fully dismantled, the base itself can be leveled by use of a transit, shooting the machined pads on the four corners. However, when a press is shipped assembled, this is not feasible. Therefore, the leveling blocks, which are machined to match the press ways, should be used with a straight edge and precision machinist's level. In all cases, final checking during the tightening of the hold-down bolts should only be done with an accurate straight edge and a high precision machinist level with graduations reading .0005 inches per foot or less, using the above mentioned leveling blocks.

When possible and time permitting, the press should be allowed to stand a minimum of twenty-four hours and then be rechecked to determine if any settling or canting has occurred. If this check shows out of level, the nuts on the foundation bolts should be loosened and the pull-down and leveling procedure repeated. This check and repetition of the procedure should be repeated until no settling or canting shows after at least a twenty-four hour period.

The above time is not lost because during these waiting periods, the sub-assemblies can be cleaned and mounted on the press.

After all components have been mounted, but before the tank is brought to the area, a final check of the level should be made.

C. Mounting of Tank

Before shipment by Farrel, the tank is drained of oil, cleaned, fully inspected and then resealed. The couplings between all motors and pumps are disconnected.

Due to our design and assembly procedure, the tank is in practice a complete hydraulic unit. The top of the tank serves as the mounting platform for pumps, motors, valves and much of the interconnecting piping. This is the heart of your extrusion press and should be treated accordingly.

Even though the tank was subject to a full cleaning procedure and inspection before shipment, a repeat of this same cleaning and inspection should be done both before the tank is raised to the top of the press and again after it is bolted in place and leveled. This cleaning should be done with a good neutral spirit solvent and by using brushes or wipers that will not leave a linty deposit. Under no circumstance should waste or linty rags be used to clean any component of a hydraulic system.

When possible, all pumps, motors, valves and inter-connecting piping are left assembled on the tank. In some cases it is necessary either for shipping purposes or because of receiving limitations to remove the pumps and motors.

In either case the tank should be moved close to the press and then, if a crane is available, by using the lifting lugs welded on the tank, the tank should be lifted into place on the machined pads on the top of the main cylinder and the stands provided for the rear of the tank. When a crane is not available, cribbing should be built up so that the tank can be raised alongside the press position, rolled into place and lowered by jacks onto the main cylinder stand. After the tank is in place, it should be leveled to become a firm level platform for the pumps and motors.

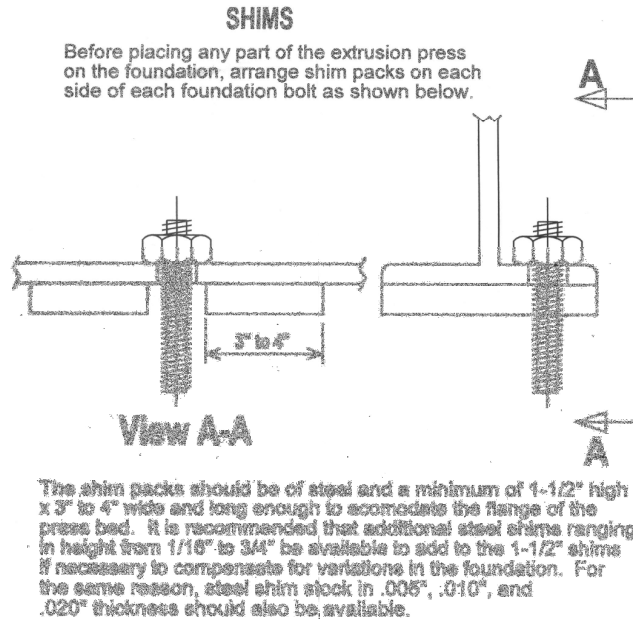

In the case of a dismantled pumping unit, you are now ready to mount the pumps and motors. All pumps and motors will be marked to replace in the position originally occupied during assembly.

At this time do not make final alignment of pumps and motors, and do not connect the coupling.

D. Piping

After the tank is in place, leveled and with the pumps and motors mounted, the piping can be reinstalled on the press.

All piping is shipped with the open ends of the pipe and the open ports on the pumps, valves, etc., covered. Regardless of these precautions, all pipes should be washed out with neutral spirit before re-assembly on the press and then blown out with clean, dry air.

A complete set of "O" rings and gaskets are shipped with the press. Care should be taken that the "O" rings and/or gaskets are carefully installed and all tightening of bolts be done in a manner to insure an even pull up of the flanges. This will give an even pressure on the complete "O" ring or gasket and reduce the possibility of leakage during startup and initial running of the press.

Particular care must be given at this time to the cleanliness of all parts and the tightening of all unions and flanges. No pipe should be forced into place. The piping has been fitted during assembly and any undue forcing at this time will establish stresses which will result in future leakage. It is not uncommon for a piece of pipe to become slightly bent during shipping. If this happens, heat should be applied to relieve any stress in re-assembly. After a piece of pipe has been heated and returned to its original shape by assembly on the press, it should be allowed to cool in place, then removed and thoroughly cleaned. Then it can be permanently re-installed on the press.

E. Wiring

All Farrel Presses are completely wired during assembly. For shipping purposes it is necessary to remove the conduit and inter-connecting wires which run between component parts of the press. All wires are numbered and, after re-installation of the conduit, should be connected to the corresponding numbered slot in the connector blocks furnished in all pull boxes.

After all the heavy components of the press and the piping have been installed, pulpits and relay panels should be put in place in preparation for wiring. These units which are physically separate from the press proper should be connected up to the press and to each other through the conduit originally installed with the foundation. When this is done, the control system will be complete.

At this time the connections from the power conduit installed with the foundation to the motors, container, and transformer should be made.

The press is now ready for final inspection, final leveling, and grouting under the supervision of a Farrel Technical Adviser.

(See *Master Builders' Bulletin* covering directions for grouting with Embeco (or equal) Grout.)

F. Final Preparations

After final leveling and grouting, the following should be done with a Farrel Technical Advisor present. These steps should be followed in the prescribed order.

1. Final inspection and cleaning of all exposed press components.
2. Final inspection, cleaning and sealing of the oil tank.
3. Filling of tank with oil.
4. Alignment of pumps and motors. Do not connect couplings.
5. Preliminary rough alignment of the press for free movement of all moving parts.
6. Turn on control power but do not turn on motor or heater power.
7. Check the control circuitry by manual operation of pushbuttons and limit switches, making sure that starters drop out with the motor stop button.
8. Only after Steps 6 and 7 have been completed satisfactorily, turn motors over to check rotation.
9. After turning motors over to check rotation, next connect all couplings.
10. With motor rotation correct jog start motors to make sure of pump suction.
11. Once motors have been started and pump suction verified, allow motors to run idle for at least one hour.
12. The press is now ready to make a manual check. With the prefill shut-off open, turn the cycle selector switch to manual and move each component of the press individually to check all interlocks. During this

period, check the position of all limit switches to make sure necessary clearances are allowed on all sequencing of the press.

13. A manual cycle should now be attempted following the right sequence for extrusion of metal.
 - a. Die slide in place - hand lever (center position)
 - b. Container on - pushbutton.
 - c. Billet loader up - pushbutton.
 - d. Main ram forward - pushbutton then hand lever.
 - e. Billet loader out - pushbutton (automatically lowered as main ram comes forward)
 - f. Main ram forward slowdown - automatic
 - g. Main ram stop and decompress - automatic
 - h. Container strip - pushbutton
 - i. Main ram return - pushbutton
 - j. Shear - pushbutton
14. After all the above manual steps are completed in sequence and all limit switches set for the desired strokes, the selector switch may be turned to auto and an automatic cycle attempted.
15. Depending on the press and the customer's requirement, there are from 2 to 6 different auto cycles. Each of these should be fully developed at this time.
16. The heat should now be turned on the container. The heat should not exceed 200°F for at least eight hours to dry out the elements and insulation. After dryout of the elements and insulation, the heat should be increased in 100° per hour increments to at least 700°F to allow for growth before final alignment of the press is made. Where possible, it is good practice to allow the container to remain at heat for twenty-four hours minimum before making final alignment. All preliminary heating should be done with the container against the die slide and the stem close to the container opening or bore heater inserted, so that the heat can penetrate the die slide and resistance platen,

G. Final Alignment and Leveling of the Press Frame

The original leveling and alignment of the press frame is done by transit and center wire during the erection of the press on the base either in the vendor's plant (in the case of a smaller press shipped as a pre-stressed unit) or in the customer's plant during final erection.

First, the inside (or die slide side) of the resistance platen and the inside face of the cylinder platen should be placed as nearly parallel as possible, with the center point of the resistance platen in line with the center point of the face of the main ram.

Both the resistance platen and the main cylinder platen faces should be perpendicular to the plane of the base.

The tie rods should be checked to be in planes parallel to the base as should the side cylinders and container sealing cylinders.

The crosshead and container housing should be aligned to the centerline established by the centers of the main ram and resistance platens. This is done by means of the adjusting shoes designed and installed in the press for adjustment of these parts.

At this point the eight nuts on the ends of the resistance platen should be adjusted to give an equal spacing between the inside face of the resistance platen and the inside face of the main cylinder platen. This is done by using a tram rod with a ballpoint on one end and a micrometer adjustment on the other. These nuts should be adjusted so that the greatest difference across corners will be .005 inches and all four should measure the designed distance between platens.

Now you are ready to pre-stress the tie rods and advance cylinders and establish the final alignment of the press frame. This is done in stages as follows:

1. With the die slide in the push-out position, seal the container (using a spacer ring to protect the container liner if necessary) and advance the main ram manually so that the stem adjusting ring (or distance piece) presses against the container with 1000 PSI.
2. Tighten all eight (8) inside split nuts.
3. Release main ram pressure and tram the platens. If the variation between corners is .005" or less, proceed to Step 4.

- 3-Alternate. If the variation is greater than .005", repeat Step #1 above, loosen all eight (8) inside split nuts, release main ram pressure and adjust nuts on the tie rods to correct variation to .005" or less. Then, repeat Steps 1, 2 and 3.
4. Repeat the procedure outlined under Step #1 above with pressure on main ram at 2000 psi.
5. Repeat Step #2.
6. Repeat Step #3.
- 6-Alternate. If the variation is greater than .005", repeat Step 3-Alt. above except main ram pressure must be slightly over 2000 psi to loosen inside split nuts. Then, repeat Steps 4, 5, and 6.
7. Repeat the procedure outlined under Step #1 above with pressure on main ram at 3000 psi.
8. Repeat Step #2.
9. Repeat Step #3.
- 9-Alternate. If the variation is greater than .005" repeat step 3-Alt. above except main ram pressure must be slightly over 3000 psi to loosen inside nuts. Then repeat Steps 7, 8 and 9.
10. Finally, repeat steps #1 and 2 above with pressure on the main ram at 3300 psi. (Relief valves must be adjusted to do this).

During Step 2, while the press is under pressure, the lock nuts on the return cylinders should be locked.

Then, release the main ram pressure and repeat step #3 above for a final check of alignment. If steps 1 thru 9 have been followed correctly, alignment should be well within .005" between all four corners of the press platens.

After the above pre-stressing is completed, the planes of the tie rods, advance cylinders, and container cylinders should be checked to make sure they are still parallel to the plane of the base, lengthwise for all and both lengthwise and cross-wise for the tie rods.

The press is now ready for the extrusion of metal.

H. Periodic Checking of the Press Frame Alignment and Level

Checks of alignment and level should be made preferably every 6 months. By means of a straightedge and high precision level, it is a simple matter to check the level of the tie rods and cylinders lengthwise and crosswise to the press.

At this time the inside split nuts and advance cylinders lock nuts should be checked for tightness and the press platens trammed as in the original alignment of the press.

Any deviation from level of the press frame during one of these checks will, about 99% of the time, reflect a change from level in the base. Rarely, if ever, will the press frame go out of level except when caused by the base going awry.

I. Installation Tools

The following tools are required for assembly and start-up and should be at hand before the customer calls for the Farrel Technical Adviser and thus eliminate delay of start-up.

1. Straight edge 8' long, 6" high, 1-1/2" wide.
2. Precision machinist level graduated between .001" to .005" per foot.
3. Complete set of Allen wrenches up to 1-1/4" hex.
4. Pipe wrenches up to 36".
5. Up to 3/4" drive socket wrench set.
6. Clamp-on type ampere tester 0-600 amp.
7. Voltage tester 0-600 volts.

If the above general outline is followed, from the preparation of the foundation to the placing in operation of the press, long, trouble-free life of the equipment should be insured. Again we stress that correct preparation, cleanliness of the area, and particular care in cleaning and handling of all components will result in a good installation, free from many of the troubles common to a new installation.

Mechanical Functions

An extrusion press consists basically of a hydraulic ram of sufficient power to push a billet into a container and then through an extrusion die. The presses themselves range in tonnage from 300 to 14000 tons of pushing power. The minimum cross-sectional area of a given profile versus the billet diameter, coupled with the aluminum alloy's extruding characteristics, will determine the capacity of the press required. We will go over the details of the various parts of the press and then tie them together in the trouble-shooting phase.

Main Ram and side Cylinders

Generally all aluminum extrusion presses built presently are made with single acting main rams and double acting side cylinders.

The primary functions of side cylinders are to advance and return the main ram at rapid speed to keep dead cycle time to a minimum. They are also used during the actual extrusion stroke to add their tonnage to that of the main ram to give the press its rated tonnage.

The main ram is only used to generate the large tonnage necessary to extrude. During the rapid advance and return motions, the main ram area must be filled with fluid to prevent cavitation. This is done, in the case of self contained-oil hydraulic presses, by prefilling from an overhead tank through a large 3-way valve.

The formula for determining the extrusion tonnage capacity of a press is:

$$\text{Tons} = \text{Area} \times \text{Pressure} / 2000$$

Area is the area of the main ram and side cylinders in square inches. Pressure is the hydraulic pressure in pounds per square inch.

The only real choice that you have in selecting piston sizes once you have determined the desired tonnage is the level of hydraulic pressure at which you want to work. Almost all the oil systems of the last 10 years have been at 3000 psi.

The pullback force of the side cylinders is figured with the same formula as above, except that the Area = Area of side cylinder pistons - Area of side cylinder piston rods. The pullback force is generally in the range of 5 to 10 percent of press capacity.

Ram Speed Calculations

The ram speeds are a function of the displaced area of the ram and the gallons that are being fed into it. The general formula for this is:

$$V = 231 \times Q/A$$

Where: V is the velocity in inches/min

Q is the gallons per minute being fed into the ram, and

A is the displaced area of the ram.

The 231 is the conversion factor to change gal/min to cubic in/min. To illustrate this a little better, let's consider the action of the side cylinders on a standard Farrel extrusion press. The initial forward motion of the rams is done on differential action, that is, the oil is directed out of the front of the side cylinders into the back so that the pumps only have to supply the rod area for speed. For an example, let's use a standard 1650 Ton press for calculation:

The side cylinders are 9" bore, 6-1/2" rod diameter, and the main ram is 35-1/4" diameter.

Side cylinders:

Bore	9" diameter	= 63.61 sqin. x 2 = 127.22 sqin.
Rod	6-1/2" diameter.	= 33.18 sqin..x 2 = 66.36 sqin.
	<i>Net area</i>	= 30.43 sqin. x 2 = 60.86 sqin.

Main ram:

Bore	35-1/4"diameter	= 975.91 sqin.
------	-----------------	----------------

Plus side cylinders"

Bore	9" diameter	= 127.22 sqin.
	<i>Total area</i>	= 1103.13 sqin.

Rapid Advance Calculation: for pump capacity 216 gpm

$$\text{Velocity} = \frac{(216 \text{ g/min})(231 \text{ in}^3/\text{g})}{66.36 \text{ in}^2} = 751.9 \text{ in/min.}$$

The 216 g/min represents the full volume of two Oilgear pumps.

Pre-Extrude Calculation

$$\text{Velocity} = \frac{(216 \text{ g/min})(231 \text{ in}^3/\text{g})}{127.22 \text{ in}^2} = 392.2 \text{ in/min.}$$

Extrude Calculation

$$\text{Velocity} = \frac{(216 \text{ g/min})(231 \text{ in}^3/\text{g})}{1103.13 \text{ in}^2} = 45.23 \text{ in/min.}$$

Return Calculation

$$\text{Velocity} = \frac{(216 \text{ g/min})(231 \text{ in}^3/\text{g})}{60.86 \text{ in}^2} = 819.8 \text{ in/min.}$$

Extrusion Tonnage Calculation

$$\text{Tons} = \frac{(1103.13 \text{ in}^2)(3000 \text{ lb/in}^2)}{2000 \text{ lb/ton}} = 1650 \text{ tons}$$

Extrusion Platen

At the other end of the extrusion press is the extrusion platen on which are mounted the gibs that retain the die slide. Mounted into the die slide is the die stack. The die stack for a normal flat type die for rod or shape sections consists of a die and die backer mounted in a die ring with this whole assembly backed up by a couple of bolsters. The function of the die stack is to transmit the extrusion force into the extrusion platen. The platen must be capable of withstanding the tonnage generated by the main ram, side cylinders, and container cylinders with acceptable stress levels and low deflection. In any comparison of one manufacturer's press to another, the platen thickness may vary and this is a result of conflicting concepts in stress calculation. This occurs because in any calculation of stress or deflection one has to assume a certain type of loading in order to complete the calculation and different viewpoints may be taken.

The extrusion platen is held in place by tie rods that connect the main cylinder and platen together. These tie rods are fitted with outer threaded nuts so that good alignment can be attained between the two platens. They are also fitted with threaded inner nuts so that an initial pre-stress can be applied to the tie rods to reduce chances of a cyclic fatigue failure of the rods. The tie rod diameters are selected on the basis of keeping stress low and the amount of stretch down to a minimum.

The extrusion platen also is the mounting mechanism of the container cylinders. They fit into bores in the platen and are retained by studs also threaded into the platen. The container cylinders are used to seal the container to the die to prevent flashing of material between die and container. They are also used to strip the butt and dummy block clear of the container after the extrusion stroke is complete.

The heavy, rigid pressure platen has a bored egress hole to accommodate and align canisters. This hole is large enough to assure efficient spreader-die operation. It can be varied in size and shape within the design limitations of the platen. In some cases, it also allows for rectangular billet extrusion. Two holes through the platen permit inspection of the dies after they are positioned in the die slide.

Butt Shear

The butt shear is a sub-assembly that is bolted and keyed to the extrusion platen. Its purpose is to shear the butt of aluminum that is left on the die face at the end of extrusion, from the die face. The shear is hydraulically operated and works at 90° to the moving action of the die slide. Because the dies for aluminum extrusion have a sharp 90° corner to the bearing surface the shearing of the butt from the die face is a simple operation.

Shears on all presses are designed with tonnage computed for the largest section which can be extruded from the press they are on. Shears are arranged so that all packing is remote from the heat radiated from the tools and material. Guidance of the shear blade holder is designed to eliminate deflection and to insure a clean cut. The blade is adjustable to compensate for different die stack thicknesses.

Base

The base is provided to support all press members on one common reference point. The main cylinder

is keyed and bolted to the base, and the extrusion platen is allowed to slide on it when the tie rods elongate from the extrusion force. The base also is the guide for the ram support and container housing. To insure ease of adjustment in the future, it is essential that very good alignment be achieved when installing the extrusion press on the foundation. Farrel recommends that it be aligned to .0005"/ft, lengthwise on the ways, across the ways, and diagonally across the ways.

Ram Support

The ram support is bolted directly to the main ram and also attaches to the side cylinders. Its function is to support the extrusion stem on the centerline of the press when the ram extends out of the cylinder. The stem adjusting ring, stem backing plate, and stem retainer are all bolted to the ram support. The ram support, like the extrusion platen, must also take all the stresses generated by the press.

Billet Conveyor and Loader

The billet conveyor is provided to bring the billet from the billet heater discharge into the press loader. The conveyor has a front shaft drive so that the chains are pulling the billet into the loader rather than attempting to push it. The chains are fitted with lugs so that the billet is kept in its correct orientation for deposit into the loader.

Farrel's loader is a pivoted arm device powered by a cylinder external to the base for easy maintenance. It is pivoted below the tie rods and swings the billet from entry position up to the center line of the press. It is fitted with adjustable plates to handle billets of the various diameters for a particular size press. A patented safety interlock prevents press operation if the dummy block is incorrectly loaded or fails to load.

Container Housing

The two-piece construction of the container housing is designed to reduce drastically the time required to change containers or heating elements. To obtain access to the container, it is only necessary to pull one quick-disconnect plug, remove four hold-down bolts, and then make a vertical lift of the top half of the housing. Another vertical lift removes the container, leaving the heating elements in the bottom half of the housing in full view for checking. With this design, the container can be changed quickly.

The container housing, which has adjustable shoes, slides on ways and maintains alignment regardless of heat expansion. The large, heavy center guide has adjustable, replaceable wear strips.

Radiant Container Heaters

With the development of the two-piece container housing, Farrel has been able to design a radiant container heating system that provides even heat, low maintenance, and important reductions in tool costs. Even heat is obtained by the number and position of the heating elements, which are mounted on a reflector plate and are isolated from the container housing. The patented control system permits rapid initial heat-up at full power and holding at set-point temperature at only one-quarter power. Operating costs are reduced and heater life is extended because the system provides an even source of power to the heating elements. All electrical connections are located on the outside of the container housing and are accessible for maintenance.

Die Slide

The three-position, horizontal, one-piece die slide, which is constructed of alloy steel, has two "U" shaped slots to accommodate the vertical loading of the dies. These are designed so that positive positioning of the die is automatic once the limiting stops have been set. The rugged, heavy construction of the die slide insures ample confinement of the tool stack and reduces distortion. A special device securely locks the die ring in place. The moving cylinder is of sufficient size to allow the die slide to be used as an auxiliary shear for shearing behind the tool stack.

Pumping Unit

The hydraulic system is designed around radial-piston-type pumps directly coupled to electric motors. This design insures smooth operation at compensated speeds which can be steplessly selected by the operator.

Container sealing at a constant high pressure during extrusion is maintained by means of a separate motor-driven pump. On all presses from 1,650 tons and up, auxiliary operations such as billet loading and oil cooling are performed by a separate low-pressure pump driven by an electric motor.

All valves and piping are designed to maintain low velocity and are rigidly mounted to eliminate shock and reduce valve-shifting time. A sight-level gauge, breather, strainer, and coolers are built into the system.

Mechanical Maintenance

Never operate a press beyond the limits set forth by the press manufacturer. When a press is designed, each member has been calculated to withstand certain limitations. Operating the press beyond the designed limitations will void any warranty, over-stress the members, and may eventually cause failure.

Schedule a regular time to clean the press, and perform the maintenance required. With a scheduled maintenance program, press down time can be minimized.

The best insurance against premature wear and fatigue is to keep the press well maintained and aligned. Alignment and proper maintenance are the factors that pay dividends in maintaining press output by eliminating costly repairs and shutdowns and permitting continuous production.

Periodic checking of the level of the base is important and should be done on a regular schedule of at least once every 6 months. The equipment necessary to do this is an accurate straightedge, high precision machinist level and two blocks machined and ground as a pair to conform to the surface of the press ways, which are integral with the base. The same accuracy as in the original leveling, (0.0005"/ft) should be maintained.

Procedure to correctly level the base: Usually if the base is found to be out of level, it will be due to a settling of the foundation at some point. To correct this condition it is necessary to jack up the low point of the base and re-level, using the same procedures as when originally leveled.

In re-leveling the base it is important that you do not attempt to jack the base and main press components up in one piece. Rather, you should use jacks to just lift the heavy components away from the base at the low point and then separately jack up and re-shim the base. Once the base has been re-shimmed to a level position, the press itself can be lowered into place on the base.

A new check of the level should now be made. If it is found that the base is still not level while supporting the weight of the press, the entire procedure should be repeated until the original reading of 0.0005 inches per foot or less is reached.

After the above, the grout should be replaced where necessary.

Checking Points:

1. Check level front to rear close to cylinder platen.
2. Check level front to rear close to resistance platen.
3. Check level left to right on front way.
4. Check level left to right on rear way.
5. Check level diagonally across ways.

Reasons for Bed Going Out of Level

1. Improper alignment of moving components or jamming of a billet between the stem and container causing a bending force on the base. This is very rare. If found, the base should be straightened before re-leveling.
2. Loosening of hold down bolts - Loss of grout and resultant shifting of shims. Should be noted before it becomes critical, by evidence of cracking grout and shifting shims. Reset the shims, tighten the bolts and proceed with a level check as covered in the preceding paragraphs.
3. The most common cause is the settling of the foundation to an uneven degree causing the base to become un-level. Correction of this condition is covered in the preceding paragraphs.

Note: After any re-leveling of the base, the press frame alignment and the alignment of the moving components must be checked, as described in the following:

- A. The tie rods should be checked to be sure they are in planes parallel to the base, as should the side cylinders and container sealing cylinders.
- B. The crosshead and container housing should be aligned to the centerline established by the centers of the main ram and resistance platens. This is done by means of the adjusting shoes designed and installed in the press for adjustment of these parts.
- C. At this point, the nuts on the ends of the resistance platen should be adjusted to give an equal spacing between the inside face of the resistance platen and the inside face of the main cylinder platen. This is done by using a tram rod with a ballpoint on one end and a micrometer adjustment on the other. These nuts should be adjusted so that the greatest difference across corners will be 0.005 inches and all four should measure the designed distance between the platens.

Now you are ready to re-stress the tie rods and crosshead advance cylinders and establish the final alignment of the press frame. By bringing the container against the die slide and advancing the main ram so that the stem holder presses against the container with slightly more than full press pressure, the tie rods will be

subject to a full stress and stretched to their permitted length, as will the crosshead cylinders.

If correction must be made to press alignment, proceed as follows:

1. Raise the clamp pressure to 10% over normal system operating pressure.
2. Loosen the inside split nuts then drop the pressure and adjust tie rod nuts.
3. To adjust or set four rods, raise the pressure to 2/3 of system pressure and re-tram. To adjust one rod, raise pressure to system operating pressure and re-tram.
4. If press trams within the 0.005" maximum allowance, raise the pressure to 10% over system pressure and lock inside split tie rod nuts.

NOTE: For complete information on pre-stressing, please refer to "Press Installation" portion of this manual.

Also, the lock nuts on the advance cylinders should be locked up under pressure to maintain them level in a plane parallel to the plane of the base.

After the above pre-stressing is completed, the planes of the tie rods, crosshead cylinders and container cylinders should be checked to make sure they are still parallel to the plane of the base, lengthwise for all and both lengthwise and crosswise for tie rods.

Once the press frame alignment and level have been established, it is time to check the level and alignment of all moving components. The following sequence has proven to be a good one to follow.

1. Main ram, side cylinder pistons and moving crosshead assembly. This assembly must be leveled in a plane parallel to the plane of the base and checked at a minimum of three points throughout its entire stroke. These three points are: full return, mid-stroke, and full stroke. At the same time, and using the same three checking positions, it should be determined that the travel of this assembly is maintained on the centerline of the press previously established when the press frame was aligned.
2. Container housing, container cylinders and container assembly. This assembly must be leveled and aligned so that the travel is in a plane parallel to the plane of the base and so that the centerline of the container bore coincides with the centerline of the press throughout its entire travel. This is done by means of the adjusting shoes provided on the container housing.
3. Extrusion stem. The mounting provided for the extrusion stem is designed so that the stem can be adjusted to a position directly on the centerline of the press. Once the stem is mounted and placed on the centerline, it should be moved forward with the main ram to a point where it enters the container. A check should now be made by either feeler gauge or taper gauge to determine that the stem and container bore are concentric.
4. Die Slide or Die Head. The die slide is pre-aligned on the horizontal centerline of the resistance platen by means of shims and wear plates. A die head is also pre-aligned by means of guide ways in the resistance platen, both on the horizontal and vertical centerlines. To align the die slide on the vertical centerline, both a stroke adjusting nut for the cylinder and positive stop pins have been provided. By means of these adjustments, the slide can be accurately aligned to the container and stem.
5. Shear. The shear guide housing is permanently keyed to the resistance platen in a position perpendicular to the plane of travel of the die slide or die head. Actually, the only alignment needed here is the spacing between the shear blade and the die face. This is usually set after heat has been applied to the container for at least 24 hours so that the container, die slide and resistance platen are at working temperature. Once this point has been reached, a hot tool stack is placed in the die slide or die head and the shear holder without a shear blade is moved down across the face of the die. With a spacer the distance between the shear blade holder and die face is accurately measured. With this measurement as a guide, the shear blade can be inserted with the correct shimming to give a clearance of 0.020 to 0.025 inches between the shear blade and die face.
6. Billet Loader. While it would have been possible to align the billet loader to the stem and container while the press was cold, it is preferable to do this after 24 hours of heating, as in the case of the shear blade. With the container sealed against a die and the main ram fully retracted, use the following procedure:
 - a. Check the arc of the arm's travel for the vertical plane and establish this plane by whatever means available.
 - b. Raise the loader to the full up position and maintain this position with controls on until the alignment procedure is complete.
 - c. Place a heavy timber under the loader arms, locked in such a manner to prevent the arm(s) from falling in the event of control or hydraulic failure during alignment.
 - d. Place a good dummy block on ram end of cradle and advance ram slowly until the pin barely makes contact with the dummy block. Now align cradle to perfectly center it on the face of the stem and make it parallel within the limits described above.
 - e. Check elevation and adjust to within limits described above.

- f. Check horizontal alignment and parallelism again.
- g. Continue this sequence until the ram end of the cradle is properly located.
- h. Place the dummy block on the container end of the cradle and follow the same procedure outlined in "d" and "g".
- i. Retract the ram and place the dummy block on the ram end of the cradle. Recheck alignment, parallelism and vertical position. If there is any discrepancy, reposition according to the above.
- j. Continue this procedure of checking back and front until the required position outlined above is attained.
- k. Lock all bolts securely and pin bolts where possible.

A check of all moving components should be made daily, especially the relationship between the stem, billet loader and container. If any misalignment is found, it should be corrected immediately.

A good working procedure would be as follows:

1. Check the stem alignment, condition, and level. It should travel in a straight line throughout its entire stroke, and travel on the centerline of the press. In its real position (full return), mid stroke and full stroke it should be parallel to the plane of the press at all times and on the centerline of the press. If any buildup of aluminum and/or deformation of the stem is noted, corrective measures should be taken. The stem should be cleaned of buildup if found. In case of deformation, the stem should be replaced.
2. Proceed with an alignment check of the billet loader as outlined in the preceding item 6 - billet loader, items "a" through "k".
3. Alignment of the container can now be checked and reestablished in relation to the stem and billet loader. The following procedure should be followed:
 - a. Seal the container against the die slide. On a press with a die slide that does not have a cold billet extraction hole, a dummy tooling set-up should be used. If the press is equipped with an extraction hole, the container can be sealed directly against the die slide.
 - b. Move the stem forward until it enters the container.
 - c. Using a taper gauge, check between the stem and container liner on the horizontal and vertical centerlines at 3, 6, 9 and 12 o'clock points. The reading should be within 0.020" at all four points. This would mean that the stem and liner are concentric within 0.010".
 - d. Now, by moving the stem forward to a point where the forward end enters the die slide or dummy tooling set-up, the same check can be made at the sealing end of the container.
 - e. If after the above checks are made any misalignment needs correction, the container should be moved away from the sealed position and the necessary adjustment made to the vertical and horizontal gibs.
 - f. The previous steps should be repeated until the measurement of 0.020" or better is reached at all checkpoints.
 - g. Once the 0.020" measurement is obtained, the container should be operated back and forth at least three times and then rechecked.
 - h. The final check can now be made by placing a dummy block on the dummy holder pin in the stem and moving the stem and dummy forward through the entire length of the container. If any binding of the dummy between the container liner and dummy holder pin is noted, a slight compensation of the stem or container can be made. If more than 0.005" correction is needed, further investigation should be made of the stem and container for deformation.
4. Once the above alignment has been checked and re-established, the die slide and shear should be checked. Very seldom will it be necessary to make adjustments to these units. However, it is good practice to maintain the die position concentric to the container. The shear itself mainly should be checked for condition of the shear blade and clearance between die face and shear blade.

Wear, Fatigue and Lubrication

Most extrusion equipment is horizontal in action, and therefore many exposed horizontal wear surfaces are unavoidable. The problem frequently is not the lubrication of these bearings, but the protection of horizontal surfaces from damage. These surfaces such as the ways of a press are hard, so that the adjustable softer wear plates sliding on them will take the wear. Dirt of all types tends to adhere to the lubricated surfaces, particularly if workers are required to step over them in their operating duties. The ways are close to the floor and dirt can be blown onto them by the many fans in the area of an extrusion press. Heavy tools and dummy blocks often are accidentally dropped on ways, and the resulting dent in the surface cannot be effectively cleaned by any wiper on the moving crosshead.

The horizontal ways of extrusion presses not only support the moving parts but center the extrusion tooling so that the high forces involved are kept concentric. If there is rapid wear, very dangerous eccentric loads can occur in the tooling. Extrusion stems could break with explosive force; bent stems are in themselves

a costly replacement and are likely to cause permanent, more costly damage to the container liner and possibly the die assembly and its supporting members.

If the main crosshead is not properly aligned, excessive wear will also take place on the main ram, main cylinder bushings, the pullback rams, the pullback ram heads, cylinders and cylinder bushings; with the possibility of bending or fatigue failure of the pullback rods. If the container holder is not properly aligned, excessive wear will take place at the center rail guide, the container shifting rams and cylinder bushings, etc., with the same possible bending or fatigue failure of the cylinder rods. All of the remaining press members are subjected to the same or similar premature wear or fatigue from lack of a preventive maintenance and alignment checking program.

The following check list should keep your press in good condition and, if adhered to along with the alignment checks covered previously, should prevent excessive maintenance and premature failure of the press members.

We have divided this short check list into daily and weekly schedules. These are based on the press being kept in a warm condition at all times at about operating temperature.

Daily Checks

- Clean and lubricate ways.
- Prior to start-up, check the press to make sure nothing is between the moving portions of the press.
 1. Is a billet with dummy block in the billet loader in the correct position?
 2. Is the container in the correct loading position?
 3. Is the dummy block being loaded into the container in the correct position behind the billet?
 4. Do the billet and dummy enter the container in a straight line without skewing?
 5. Does the container move squarely away from the die when stripping the butt and dummy block?
 6. Does the shear blade clear the die face when shearing the butt and dummy block?
 7. Do the dummy block and butt fall clear after shearing so that the dummy does not hit the container and neither hangs up so as to be caught on the next container closing stroke?
- The air dryer must be drained every eight hours or on start-up of each shift.
- Drain any condensation from the bottom of air filters as well as the main air collector reservoir, if installed.
- Check the limit switch interlock to stop the main ram forward travel, if the billet loader is not down.
- Grease the shear, die slide, container shoes, loader pivots, and crosshead shoes at least once every eight hours. Shoes on the crosshead may run dry and will have to be lubricated more often. Use high temperature grease.

Weekly Checks

- Check alignment of the die slide, stem and container (hot).
- Check the face of the pressure ring in the front platen for coining and parallelism.
- Check the tie rod nuts to make sure they are tight.
- Check the nuts on container and crosshead cylinder pistons to make sure they are tight..
- Check all gland bushing nuts to make sure they are tight.

If the press is operated only on one shift or is shut down over a period such as a weekend the following precautions are recommended:

1. Hydraulic Rams: Do not leave the press for any period of time with rams extended as dust and dirt settlement on ram surfaces can cause excessive wear.
2. Temperature Check: After a shutdown of 8 hours or more check the temperature of the container liner, container, extrusion stem, dummy block, die and die tooling, and billet before operating. A container bore heater is recommended to keep the container warm during the shut-down. It is a good idea to keep the container on low heat along with the bore heater, as well as keeping the container close to the die slide to prevent heat loss.
3. Alignment Check: After a shutdown of 8 hours or more, the first billet should be loaded into the container and extruded using the manual press controls to make certain that the loader lines up with the stem and container, the container lines up with the die, and the shear blade lines up with the die. It is doubtful that the press alignment would be disturbed by a short shutdown, but perhaps an adjustment was changed during the last operating shift and the adjustment must be remade due to changed conditions.

Lubrication

Grease moving parts as required. Press manufacturers will indicate frequency of greasing in their

instruction manual. Have a grease gun available at each press. Take the time to make a sketch of the fitting locations and frequency of greasing. Attach the sketch to the press for the convenience of maintenance and operating personnel.

Grease fittings are located at the ends of the electric motors for lubrication of the motor bearings. Standard motors are provided with two bearing chamber openings. One opening is intended as a relief for pressure gun filling. Remove plugs, pump in grease; the excess will be forced out through the relief opening instead of out the motor shaft seal. Where a second opening is not provided, use care in filling the chamber with grease. Excess grease could be forced out the motor seals into the motor.

Grease couplings between the motors and pumps. Remove the two pipe plugs in the coupling sleeve. Insert a grease fitting in one side, fill with grease until it comes out the other hole, remove grease fitting, and re-install pipe plugs. Some couplings may require disassembly to repack with grease.

Use a high temperature lubricant such as Fel-Pro, Molycote, etc., on all cap screws subject to high temperature. Cap screws subject to high and low temperatures form an oxidation around the threads. The high temperature grease will lubricate the threads to prevent galling when the cap screws are removed.

Packing

Main cylinder ram seals and side cylinder seals are of chevron type packing. The following procedure should be adhered to when replacing packing, and when handling packing. When replacing packing, use the same type as recommended by the press manufacturer.

When packing starts to wear, replace it, otherwise parts of the packing will contaminate the oil and work into the pumps or valves, thus causing damage.

Before installing packing, inspect each piece for nicks, cuts, flaws or dirt. All metal surfaces on which the packing slides should be very smooth. The closer the surface is to a mirror finish, the more efficiently the packing will operate. If the metal surfaces are scratched or nicked, blend them with a honing stone. Soak the packing in hydraulic oil before installing it.

Sharp instruments should not be used when installing packing. Use a wooden stick with rounded edges when pressing new packing into place.

Main cylinder packing is installed as follows:

1. Two rings with adapter against suction and (6) rings with adapters against pressure.
2. Get packing in evenly and snugly without using undue force.
3. Tighten the packing retaining glands evenly and only enough to prevent leakage. Packing which is too tight may:
 - Increase frictional resistance
 - Wear out much more rapidly
 - Cause abrasion of metal surface.

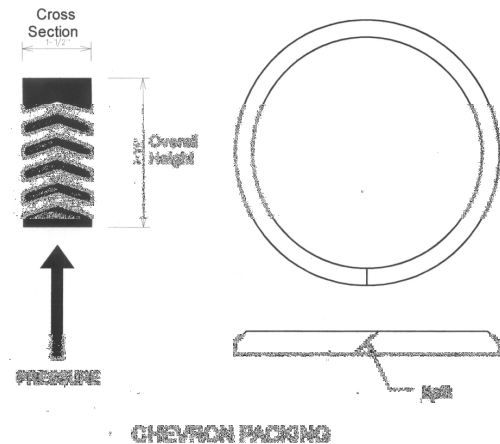

Installation of chevron type packing:

- A. Installation of each ring of a set must be done separately. Make sure the first two packing ring splits are located 180° apart from each other. Then rotate the second set of two by 90° and again index each 180°; rotate 3rd set another 90° and index at 180°.
- B. Be sure each ring is seated properly.

Spare Parts

Our instruction manuals contain a list of recommended spare parts. It may be possible to manage without spares of certain items on the list, such as ram packing and bushings; but it is not advisable. There are items on the list that should be maintained as spares. The items are:

- A. Coils for relays and solenoids
- B. Heater elements and thermocouples
- C. “O” rings and gaskets.

A failure of any of the above items would cause a press to be shut down. The length of time the press is down would be dependent on availability of the parts. It takes time for any press manufacturer to process an order for replacement parts. Consider the lost time and cost of ordering parts when a press is down.

- A. Cost of phone call and time involved to order part.
- B. Amount of time the press manufacturer takes to process the order.
- C. Availability of material from press manufacturer's stock.
- D. Availability of transportation to get the part to the customer's plant.

Notes: *This page intentionally blank*

Correct Bolting Procedures

The idea for this section comes from a paper² presented at ET16 by James Cunningham, Cunningham Mechanical Design, Inc. Text and graphics used here are from various internet sources as indicated.

“Bolting torque and tensioning practices for assembly and maintenance purposes can be improved by applying the correct methods. Loose or over-tightened bolts and screws pose a problem for mechanical, electrical, hydraulic, and pneumatic components. Bolts that are not properly torqued pose a risk to both the equipment and personnel operating the equipment. Using proper procedures when applying torque to a bolted connection can improve the functionality and longevity of the mating components.³”

The illustrations on following pages show the different types of fasteners, including bolts, screws, nuts, and washers, including charts for identifying thread pitch and bolt grades. It is critical to always use the correct type of fasteners specified for the design of the connection, and to apply the correct torque.

“It is important to recognize the type of threading used on the fastener. There are many different thread forms that are available for threaded fasteners. However, the author will focus on the two types that are most commonly used on our applications. Most of the fasteners that you will use have what is defined as a coarse thread (UNC). This is most typical for hex head, socket head, and flat head cap screws. The other thread form that one may find on the equipment worked on will be what is defined as fine thread (UNF). The distinction between the two is easily recognized by the threads per inch. This is a standard term used for thread form. Basically, one counts the number of threads per inch of length of the fastener. Fine thread fasteners have a very small thread to adjacent thread distance, whereas coarse threads are more spaced out on the length of the bolt. These designations can also be found on bills of material and/or supply lists for the mechanical assembly. Typical designations include the bolt diameter, number of threads, and type of thread form. Some examples are:

- 0.50-13 UNC (1/2" diameter, 13 threads per inch, coarse thread form)
- 0.50-20 UNF (1/2" diameter, 20 threads per inch, fine thread form).

² Cunningham, James, “Review of Proper Bolting Practices – Applying Torque or Tension to a Bolted Connection,” *Proceedings of 11th International Aluminum Extrusion Technology Seminar*, (2016), p.521-535.

³ *ibid*

The following are various examples of fine and coarse threaded fasteners.

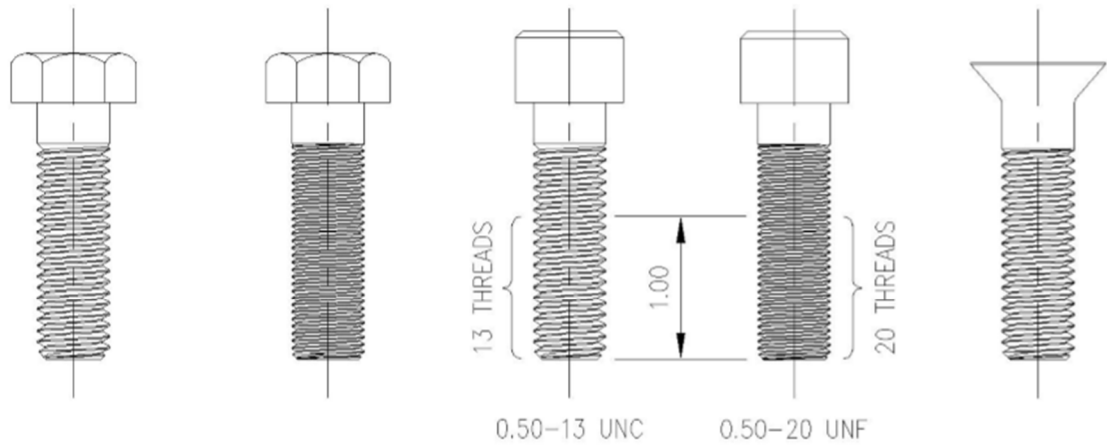
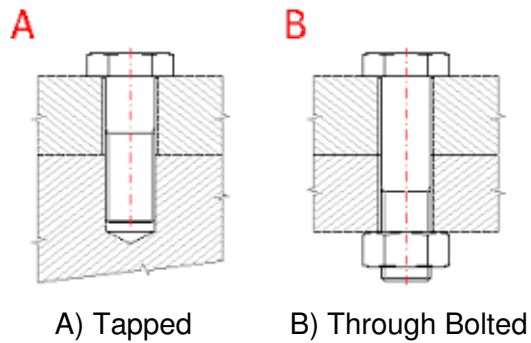

Figure 2. From left to right: coarse thread hex head cap screw; fine thread hex head cap screw; coarse thread socket head cap screw; fine thread socket head cap screw; and coarse thread flat head cap screw.

Standard Types of Mechanical Bolted Connections



Fastener Basics

Fastener Basics



Common Fastener Types



Hex bolts, or *hex cap screws*, are used in machinery and construction. Can be used with a nut, or in a tapped hole. Fully threaded hex bolts are also known as *tap bolts*.



Wood screws have large threads and a smooth shank for pulling two pieces of material together. They can be used in wood and other soft materials.



Sheet metal screws have sharp points and threads, and are designed to be driven directly into sheet metal. They can also be used in softer materials like plastic, fiberglass, or wood.



Machine screws are fully threaded for use with a nut or in a tapped hole. Certain types are sometimes referred to as *stove bolts*.



Socket screws are machine screws with an internal hex socket (*Allen*) drive. Longer lengths may have a smooth shank.



Lag bolts, or *lag screws*, are large wood screws with hex heads. Typically used for wood construction and landscaping.



Carriage bolts have smooth, domed heads with a square section underneath that pulls into the material to prevent spinning during installation.



Nuts are used to fasten machine threaded fasteners in through-hole applications. *Lock nuts* help prevent loosening.



Washers spread the load over a greater surface area when tightening a bolt, screw or nut. *Lock washers* help preventing loosening.

Tip: Find a more comprehensive fastener type chart at <http://boltdepot.com/info>

Grade / Class and Fastener Strength

Fastener **Grade** (US) or **Class** (metric) refers to the mechanical properties of the fastener material. Generally, a higher number indicates a stronger, more hardened (but also more brittle) fastener.

For a chart of fastener grades, head markings and mechanical properties, see Bolt Depot's Grade markings and Strength Chart at <http://boltdepot.com/info>

US bolt head markings



Grade 2

Grade 5

Grade 8

Metric bolt head markings



8.8

10.9

12.9

Note: In addition to these markings, the head will often have a manufacturer stamp.

Fastener Materials

Note: Do not rely on this guide for color-matching. The appearance of these materials sometimes differs significantly from the photos below.

Zinc-plated steel is a low carbon steel for general use. Relatively inexpensive, with the zinc plating providing moderate corrosion resistance suitable for indoors or otherwise dry conditions. Color is either a blue-ish tint or yellow depending on the exact process.



Hot-dipped galvanized steel has a thicker zinc coating for better corrosion resistance, making it suitable for outdoor use. Because of the thick plating, only galvanized nuts and washers will fit galvanized bolts. The coating typically has a rough, dull grey finish.



Stainless steel offers good corrosion resistance, making it suitable for outdoor and marine applications, but is more expensive than zinc plated.



Chrome and nickel plated steel are smooth and polished for appearance. The plating offers moderate corrosion resistance.



Brass and bronze are copper alloys with good corrosion resistance. More expensive than steel, these materials are typically used for decorative applications. Colors can vary significantly.



Alloy steel is highly hardened and usually black oxide and/or oil coated, offering little corrosion resistance.



How Fasteners are Notated: An Example



Machine screws, Phillips pan head, Stainless steel 18-8, #12-24 x 1"

Fastener type

Material

Diameter
Thread Count (TPI)
Length

Drive Types



Phillips



Frearson



Pozi driv



Slotted



Combo



Hex socket (Allen)



Square (Robertson)



Torx

Phillips and Slotted drives are common in screws, but prone to cam-out (stripping). **Combo** drives, that can be used with either driver, are available for many fastener types.

Frearson and Pozi driv are similar to Phillips, but less prone to cam-out.

Hex socket (Allen) drives are compact and easy to drive, but prone to cam-out.

Torx and Square drive are resistant to cam-out and can be installed single-handed.

Note: Most drive types (Frearson and Slotted being notable exceptions) require the correct driver size for proper installation.

Head Styles



Hex heads are typically used with larger bolts and screws, and tightened with a wrench.



Pan heads have a slightly domed head that sits above the surface.



Flat heads are installed in a countersunk hole for a flat surface.



Round heads are tall domed heads, used primarily for decorative purposes.



Oval heads are a low domed and countersunk heads, used primarily for decorative purposes.



Truss heads are slightly domed, with a wide head for an extra large surface area.



Socket heads are narrow with a socket drive, and knurled or smooth sides.



Button heads feature a medium dome. Typically used with a hex socket drive.

Measuring Diameter

For most types of fasteners, the diameter is measured on the **outside of the threads**.

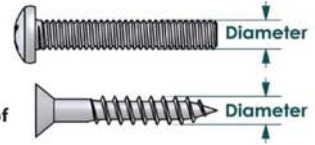

Note: US diameters under 1/4" are given as numbers (e.g. #12) instead of inches, in order of increasing size. If you need to find the actual diameter, use a table corresponding to your fastener type at <http://boltdepot.com/info>

Thread Count and Thread Pitch

Machine threaded fasteners specify a thread density in **Threads Per Inch** (US) or as a **Thread Pitch** in mm (Metric).

For a given diameter, a fastener may be available in **coarse** (standard), **fine** and sometimes **super fine** thread.

Measuring Length

Fastener length is usually measured from where the material is assumed to be to the end of the fastener.



Thus, countersunk fasteners are measured overall and non-countersunk fasteners are measured from under the head.

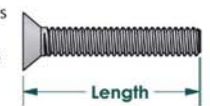

Nut and Washer Sizes

Nut and washer sizes indicate **the screw or bolt they fit**. For example:



Different washer patterns have different **outside diameters**. For example, hardened US washers are available in **USS** (wider) and **SAE** (narrower) patterns. **Fender washers** have large outside diameters.

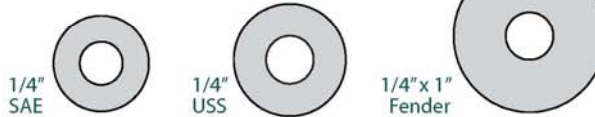

More Information

At <http://boltdepot.com/info> you'll find:

- **In-depth fastener info**
- **Charts and tables**
- Printable **lay-over charts** and **tools** for quickly identifying fastener sizes and types
- Much more...



Nut Types



Hex
A six sided nut. Also referred to as a Finished Hex Nut.



Heavy Hex
A heavier pattern version of a standard hex nut.



Nylon Insert Lock
A nut with a nylon insert to prevent backing off. Also referred to as a Nylock.



Jam
A hex nut with a reduced height.



Nylon Insert Jam Lock
A nylock nut with a reduced height.



Wing
A nut with 'wings' for hand tightening.



Cap
A nut with a domed top over the end of the fastener.



Acorn
Acorn nuts are a high crown type of cap nut, used for appearance.



Flange
A nut with a built in washer like flange.



Tee
A nut designed to be driven into wood to create a threaded hole.



Square
A four sided nut.



Prevailing Torque Lock
A non-reversible lock nut used for high temperature applications.



K-Lock or Kep
A nut with an attached free-spinning external tooth lock washer.



Coupling
Coupling nuts are long nuts used to connect pieces of threaded rod or other male fasteners.



Slotted
Slotted nuts are used in conjunction with a cotter pin on drilled shank fasteners to prevent loosening.

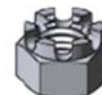

Castle
Castle nuts are used in conjunction with a cotter pin on drilled shank fasteners to prevent loosening.

Washer Types



Flat
A flat washer, used to distribute load. Available in SAE, USS and other patterns.



Fender
An oversize flat washer used to further distribute load especially on soft materials.



Finishing
A washer used to obtain a 'finished' look. Usually used with oval head screws.



Split Lock
The most common style of washer used to prevent nuts and bolts from backing out.



External Tooth Lock
A washer with external 'teeth'. Used to prevent nuts and bolts from backing out.



Internal Tooth Lock
A washer with internal 'teeth'. Used to prevent nuts and bolts from backing out.

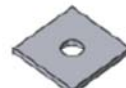

Square
A square shaped washer.



Dock
Dock washers have a larger outside diameter and are thicker than standard.



Ogee
Thick, large diameter, cast iron washers with a curved or sculpted appearance. Typically used in dock and wood construction.



Sealing
A soft neoprene washer bonded to a metal backing. Used to seal out air/water or dampen noise and vibration.

Standard US Hex Bolt Sizes and Thread Pitches

www.boltdepot.com/tools

Bolt Depot.com
fastener shopping made easy

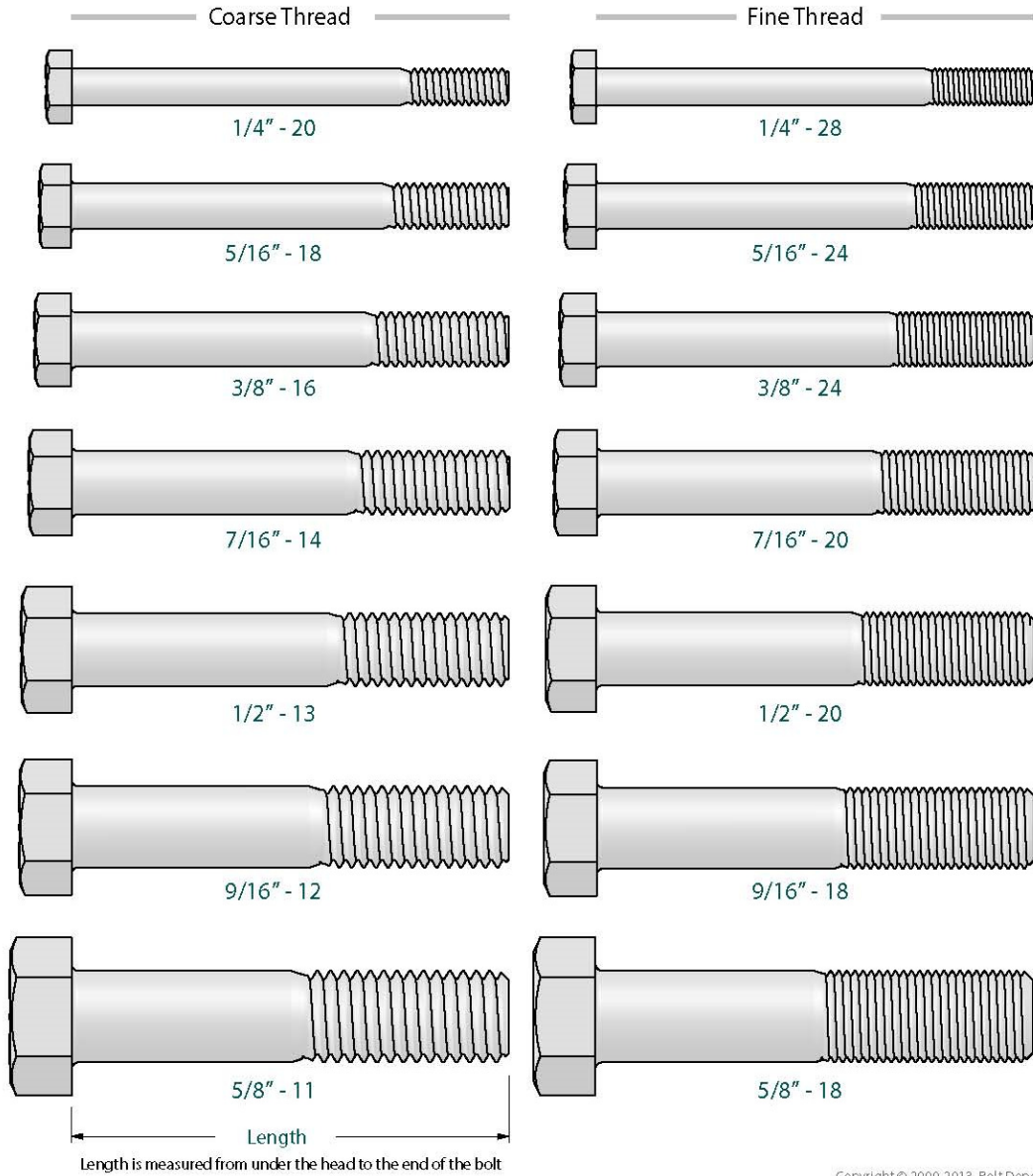

Copyright © 2000-2013 BoltDepot, Inc.

IMPORTANT: Make sure to print this chart to Actual Size (no scaling).
After printing, measure the scale check below to ensure correct scale. See boltdepot.com/tools for more details.



Standard US Machine Screw Sizes



www.boltdepot.com/tools

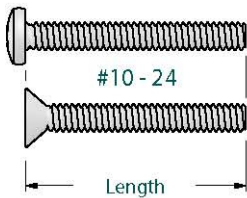
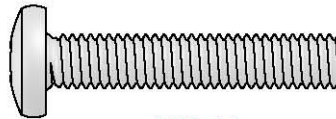
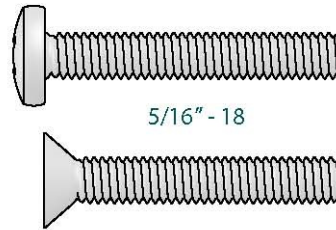
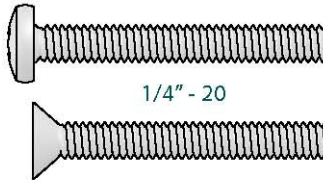
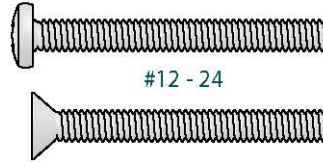

Length is measured from where the surface is assumed to be, to the end of the screw. Therefore, pan head screws are measured from under the head, and flat head screws are measured overall.

Copyright © 2000-2013 Bolt Depot Inc.

IMPORTANT: Make sure to print this chart to Actual Size (no scaling).
After printing, measure the scale check below to ensure correct scale. See boltdepot.com/tools for more details.



Standard Metric Hex Bolt Sizes and Thread Pitches



www.boltdepot.com/tools

(Note: Head sizes may differ from what is shown due to differences between metric standards)

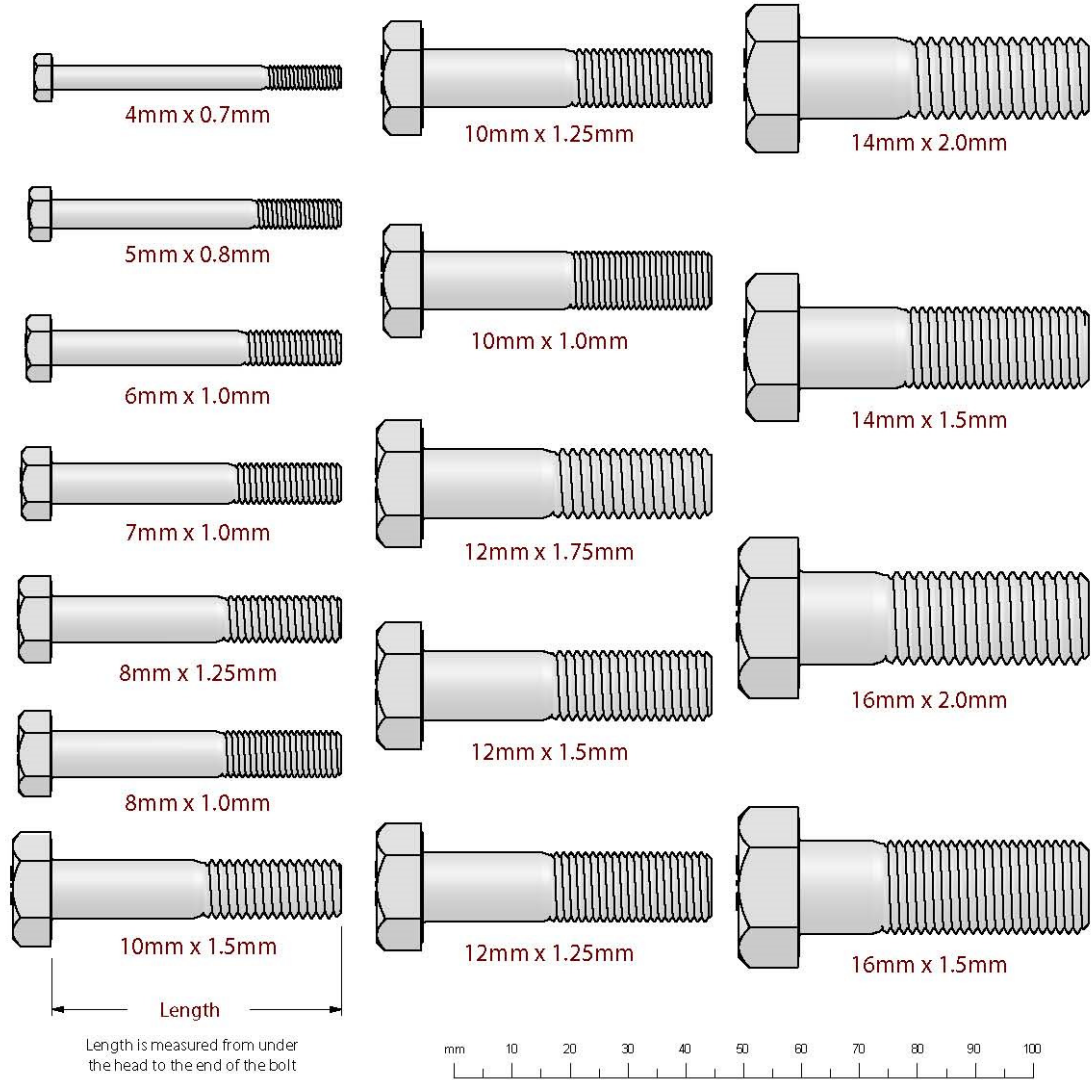

Copyright © 2000-2013 Bolt Depot Inc.

IMPORTANT: Make sure to print this chart to **Actual Size** (no scaling). After printing, measure the scale check below to ensure correct scale. See boltdepot.com/tools for more details.



US Nut Size Chart

www.boltdepot.com/tools

Bolt Depot.com
fastener shopping made easy

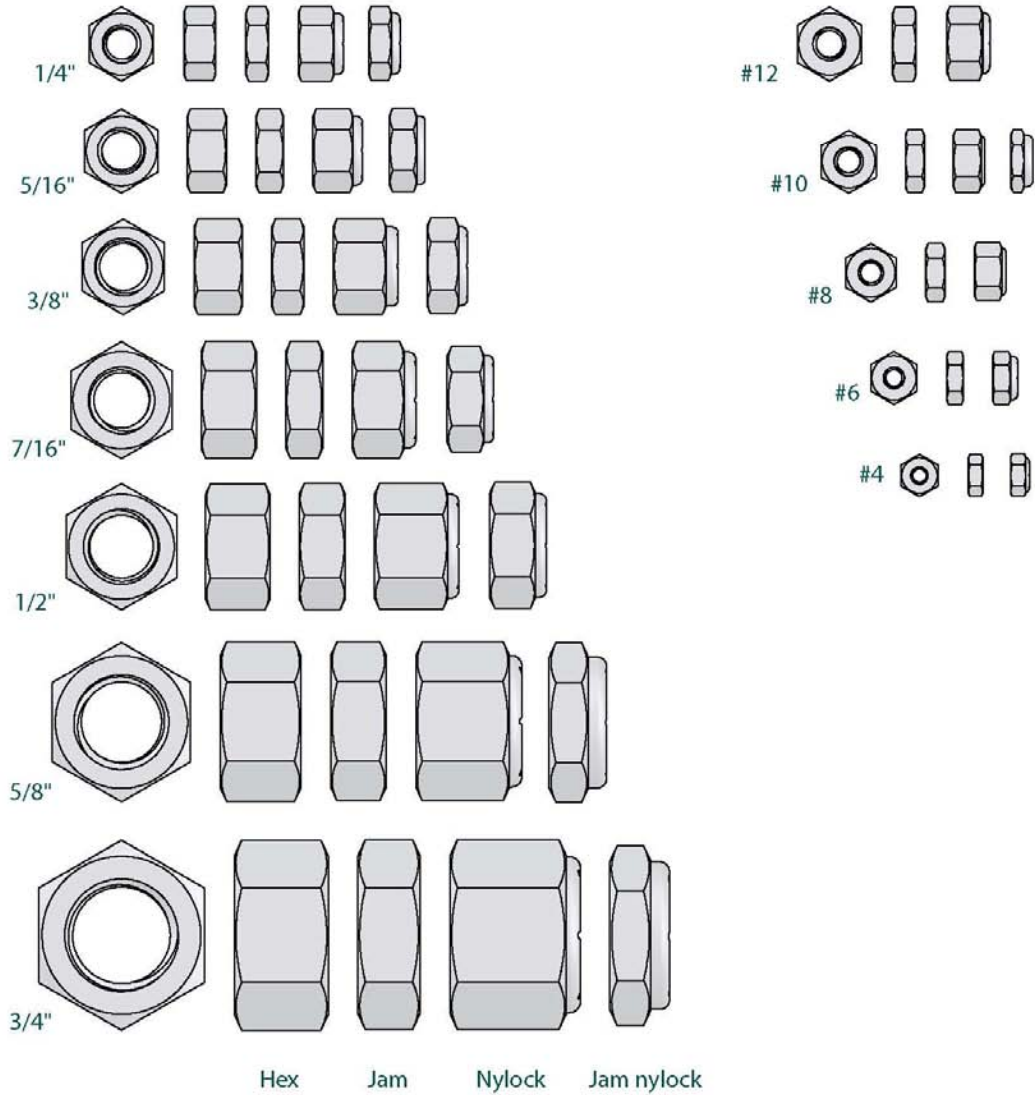

Copyright © 2000-2013 Bolt Depot Inc.

IMPORTANT: Make sure to print this chart to **Actual Size** (no scaling).
After printing, measure the scale check below to ensure correct scale. See boltdepot.com/tools for more details.



Metric Nut Size Chart



www.boltdepot.com/tools

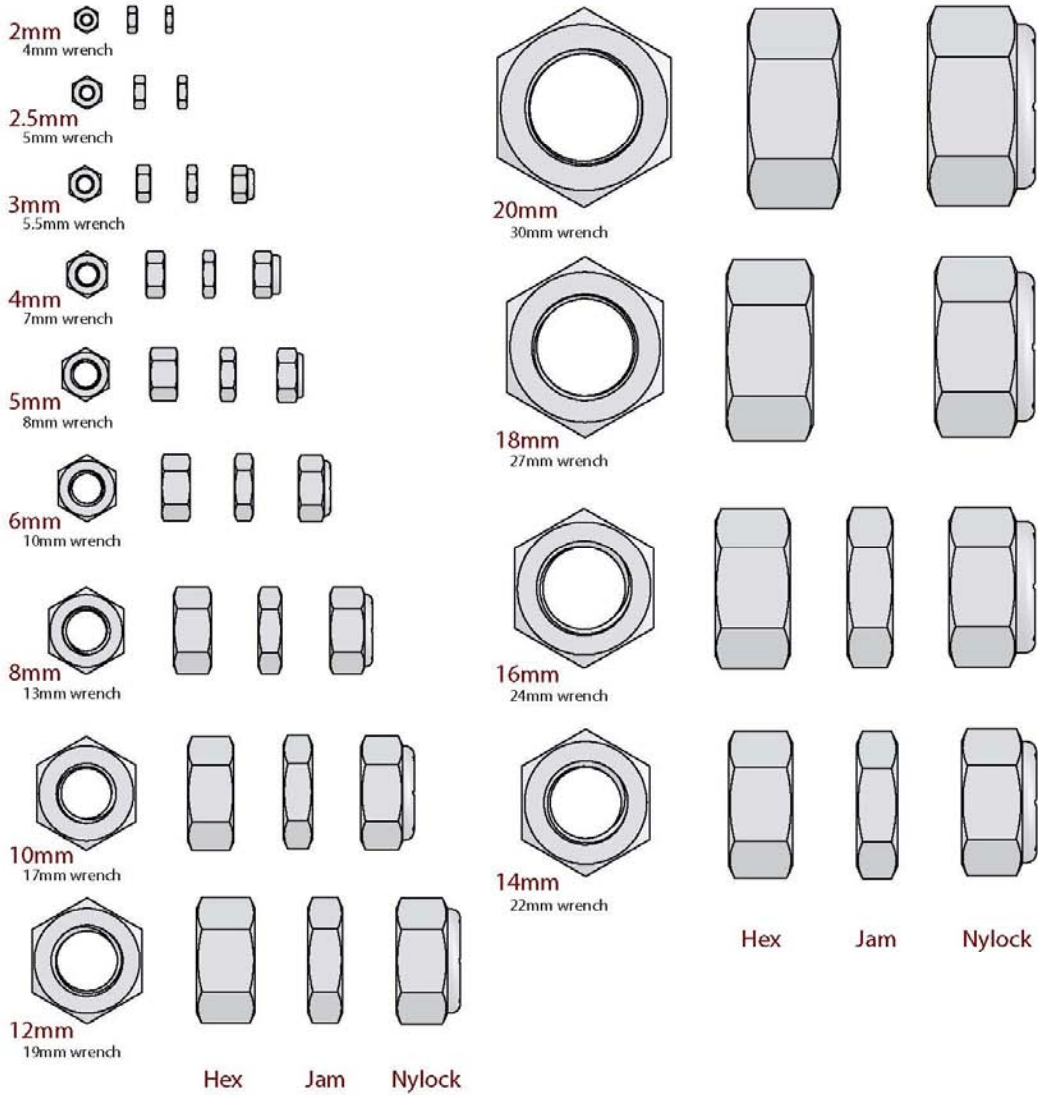

Copyright © 2000-2013 Bolt Depot Inc.

IMPORTANT: Make sure to print this chart to **Actual Size** (no scaling).
 After printing, measure the scale check below to ensure correct scale. See boltdepot.com/tools for more details.



US and Metric Thread Sizes



www.boltdepot.com/tools

US Thread Sizes



7 tpi

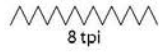

8 tpi

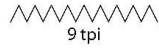

9 tpi

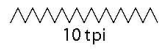

10 tpi

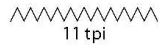

11 tpi

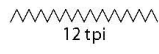

12 tpi

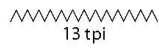

13 tpi

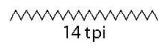

14 tpi

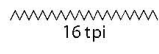

16 tpi

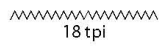

18 tpi

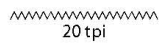

20 tpi

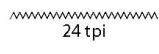

24 tpi

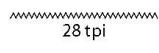

28 tpi

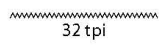

32 tpi



40 tpi

Metric Thread Pitches



2.5 mm



2.0 mm

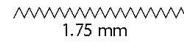

1.75 mm

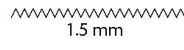

1.5 mm

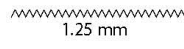

1.25 mm

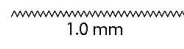

1.0 mm



0.8 mm

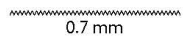







0.7 mm

Copyright © 2000-2013 Bolt Depot Inc.

IMPORTANT: Make sure to print this chart to **Actual Size** (no scaling).
After printing, measure the scale check below to ensure correct scale. See boltdepot.com/tools for more details.

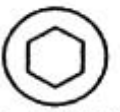

Bolt Grades and Yield Strengths

MINIMUM STRENGTHS	
METRIC (ISO 898)	INCH (SAE J429)
	
Grade: 4, 8 (4.6, 5.8) Tensile: 429 MPa (60,900 psi)	Grade: 2 Tensile: 60,000 psi
	
Grade: 8.8 Tensile: 830 MPa (120,350 psi)	Grade: 5 Tensile: 120,000 psi
	
Grade: 10.9 Tensile: 1040 MPa (150,800 psi)	Grade: 8 Tensile: 150,000 psi
	
Grade: 12.9 Tensile: 1220 MPa (176,900 psi)	Grade: ASTM-A574 Tensile: 170,000 psi Note: Generally not marked

“The two grades that one will primarily find on [extrusion] equipment are grade 5 and grade 8. These numbers represent the steel alloy used to manufacture the bolt. Grade 5 is a lesser alloy than grade 8 and therefore, grade 8 bolts are used for higher load applications such as the prefill valve attached to the back end of the main cylinder. There are many other lower-graded bolts that are used for other applications. Mating two components that do not have a load imparted on them may only require a lesser-grade bolt. However, the large equipment that the author and his colleagues work on requires these higher-grade bolts.”

Correct Bolt Tension

In a bolted connection, torque is applied to place the bolt in tension with the effect of a spring. The threads should be lubricated before assembly in order to reduce the torque required to apply the correct tension. Next the connection is tightened “hand tight” so that nut and bolt are in full contact with the flange surfaces before the tension load is applied.

Setting the correct bolt tension is done by either the **turn-of-nut method**, or by use of devices that apply a measured amount of torque.

Turn-of-Nut Method

With the nut and bolt in a hand-tight or snug position, the nut is marked as indicated below, and then tightened according to the tables to achieve the desired tension. The marks indicate the degree of rotation. All bolts on a flange are marked and tightened the same.

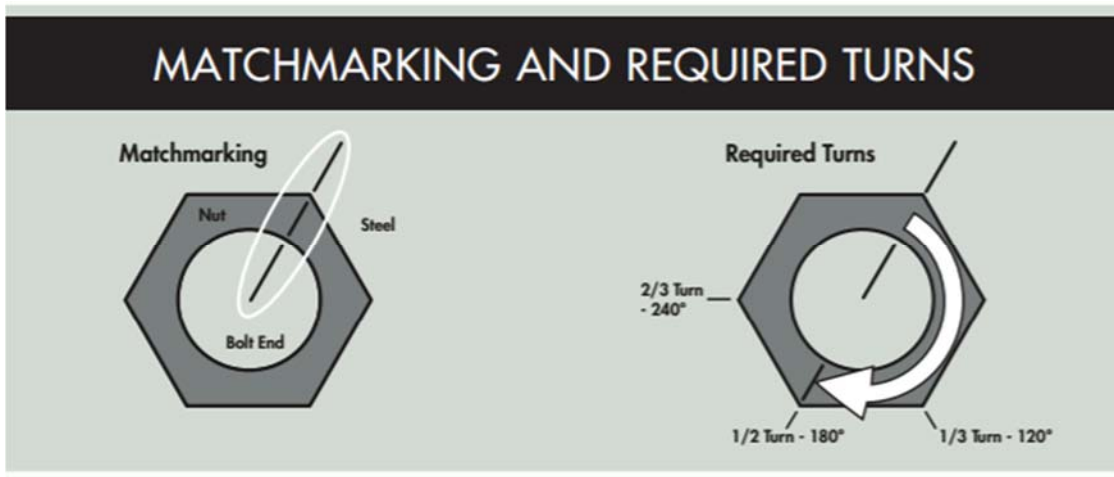

TURN-OF-NUT METHOD REQUIRED TURNS FOR PRETENSIONING FROM SNUG-TIGHT

Flat Surfaces under Bolt Head and Nut

BOLT DIAMETER (INCHES)	BOLT LENGTH TO 4D	REQUIRED TURNS	BOLT LENGTH OVER 4D TO 8D	REQUIRED TURNS	BOLT LENGTH OVER 8D TO 12D	REQUIRED TURNS
1/2"	2"	1/3 turn	>2 to 4"	1/2 turn	>4 to 6"	2/3 turn
5/8"	2.5"	1/3 turn	>2.5 to 5"	1/2 turn	>5 to 7.5"	2/3 turn
3/4"	3"	1/3 turn	>3 to 6"	1/2 turn	>6 to 9"	2/3 turn
7/8"	3.5"	1/3 turn	>3.5 to 7"	1/2 turn	>7 to 10.5"	2/3 turn
1"	4"	1/3 turn	>4 to 8"	1/2 turn	>9 to 13.5"	2/3 turn
1 1/8"	4.5"	1/3 turn	>4.5 to 9"	1/2 turn	>10 to 15"	2/3 turn
1 1/4"	5"	1/3 turn	>5 to 10"	1/2 turn	>11 to 16.5"	2/3 turn

(Information from RCSC Table 8.2)

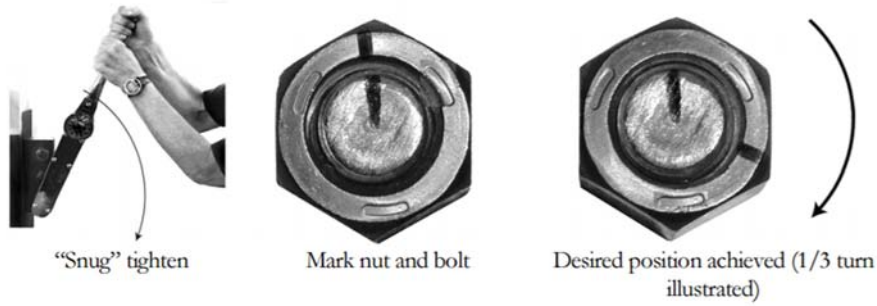

Bolt Length	Condition Under Bolt Head and Under Nut		
	Both Faces Flat (normal to bolt axis)	One face sloped, but not more than 1:20	Both faces sloped, but not more than 1:20
Less than or equal to 4D	1/3 Turn	½ Turn	2/3 Turn
More than 4D and less than or equal to 8D	½ Turn	2/3 Turn	5/6 Turn
More than 8D and less than or equal to 12D	2/3 Turn	5/6 Turn	1 Turn

D = Bolt Diameter
Applicable only to steel joints

To use the turn-of-nut method it is necessary to know the bolt length, diameter, and thread pitch.

Torque-Applying Devices

The most accurate methods for precisely loading a bolted connection involve devices such as torque wrenches and hydraulic torque tools. First, calculate the amount of tension desired by referring to a manufacturer's chart or another accredited source to determine the amount of tension to be applied. One chart is reproduced below.

Most bolted applications do not require the highly accurate tensioning method, but rather a range to which the bolt should be stretched. This is when torque tools are to be used. Manufacturers may or may not provide an actual torque chart for their bolting applications. If they do not, there are many charts available online that can be easily found. Each chart used should be verified by an engineer for having the desired torque listed. Once the torque for the application is defined, a torque tool can be used to achieve the residual load in the bolted connection.

The correlation between bolt tension and applied torque depends on the friction in the threads, so the use of lubricants can greatly reduce the co-efficient of friction and thereby reduce the amount of torque required to properly make a bolted connection. Many torque charts offer a range of torque, along with variations depending on the lubricant used. These charts may have torque values for bare steel, light oil, nickel, and molybdenum lubricants. Using the different lubricants is critical to reducing the co-efficient of friction, and in turn reducing the range of applied torque.

FASTENER TORQUE CHARTS

	BOLT CLAMP LOADS									
	Suggested Assembly Torque Values									
	USS/SAE GRADE 5					USS/SAE GRADE 8				
DIAMETER & THREADS PER INCH	TENSILE STRENGTH Min. PSI	PROOF LOAD LB	CLAMP LOAD LB	TORQUE Dry FT LB	LUBRICATED FT LB	TENSILE STRENGTH Min. PSI	PROOF LOAD LB	CLAMP LOAD LB	TORQUE Dry FT LB	LUBRICATED FT LB
1/4-20 28	120,000	2,700	2,020	8	6.3	150,000	3,800	2,850	12	9
	120,000	3,100	2,320	10	7.2	150,000	4,350	3,250	14	10
5/16-18 24	120,000	4,450	3,340	17	13	150,000	6,300	4,700	24	18
	120,000	4,900	3,700	19	14	150,000	6,950	5,200	27	20
3/8-16 24	120,000	6,600	4,950	30	23	150,000	9,300	6,900	45	35
	120,000	7,450	5,600	35	25	150,000	10,500	7,900	50	35
7/16-14 20	120,000	9,050	6,780	50	35	150,000	12,800	9,550	70	50
	120,000	10,100	7,570	55	40	150,000	14,200	10,650	80	60
1/2-13 20	120,000	12,100	9,050	75	55	150,000	17,000	12,750	110	80
	120,000	13,600	10,200	85	65	150,000	19,200	14,400	120	90
9/16-12 18	120,000	15,500	11,600	110	80	150,000	21,800	16,350	150	110
	120,000	17,300	12,950	120	90	150,000	24,400	18,250	170	130
5/8-11 18	120,000	19,200	14,400	150	110	150,000	27,100	20,350	210	160
	120,000	21,800	16,350	170	130	150,000	30,700	23,000	240	180
3/4-10 16	120,000	28,400	21,300	260	200	150,000	40,100	30,100	380	280
	120,000	31,700	23,780	300	220	150,000	44,800	33,500	420	310
7/8-9 14	120,000	39,300	29,450	430	320	150,000	55,400	41,600	600	450
	120,000	43,300	32,450	470	350	150,000	61,100	45,800	670	500
1-8 14	120,000	51,500	38,600	640	480	150,000	72,700	54,500	910	680
	120,000	57,700	43,300	720	540	150,000	81,500	61,100	1,020	760

Additional charts at <http://www.repairengineering.com/bolt-torque-chart.html>



Torque Wrenches



Torque Screwdriver

Pneumatic Torque Wrench



Hydraulic Torque Wrench



Flange Bolt Tightening Sequence

When tightening flange bolts follow the number sequence below to assure uniform tightening.

